

## Low Voltage Alternators - 4 pole

**TAL A40 - TAL A42- TAL A44**

Electrical and mechanical data

13 to 200 kVA - 50 Hz / 15.5 to 250 kVA - 60 Hz

**LEROY-SOMER**<sup>™</sup>

***Nidec***  
All for dreams

# Product Feature

## Features and Benefits

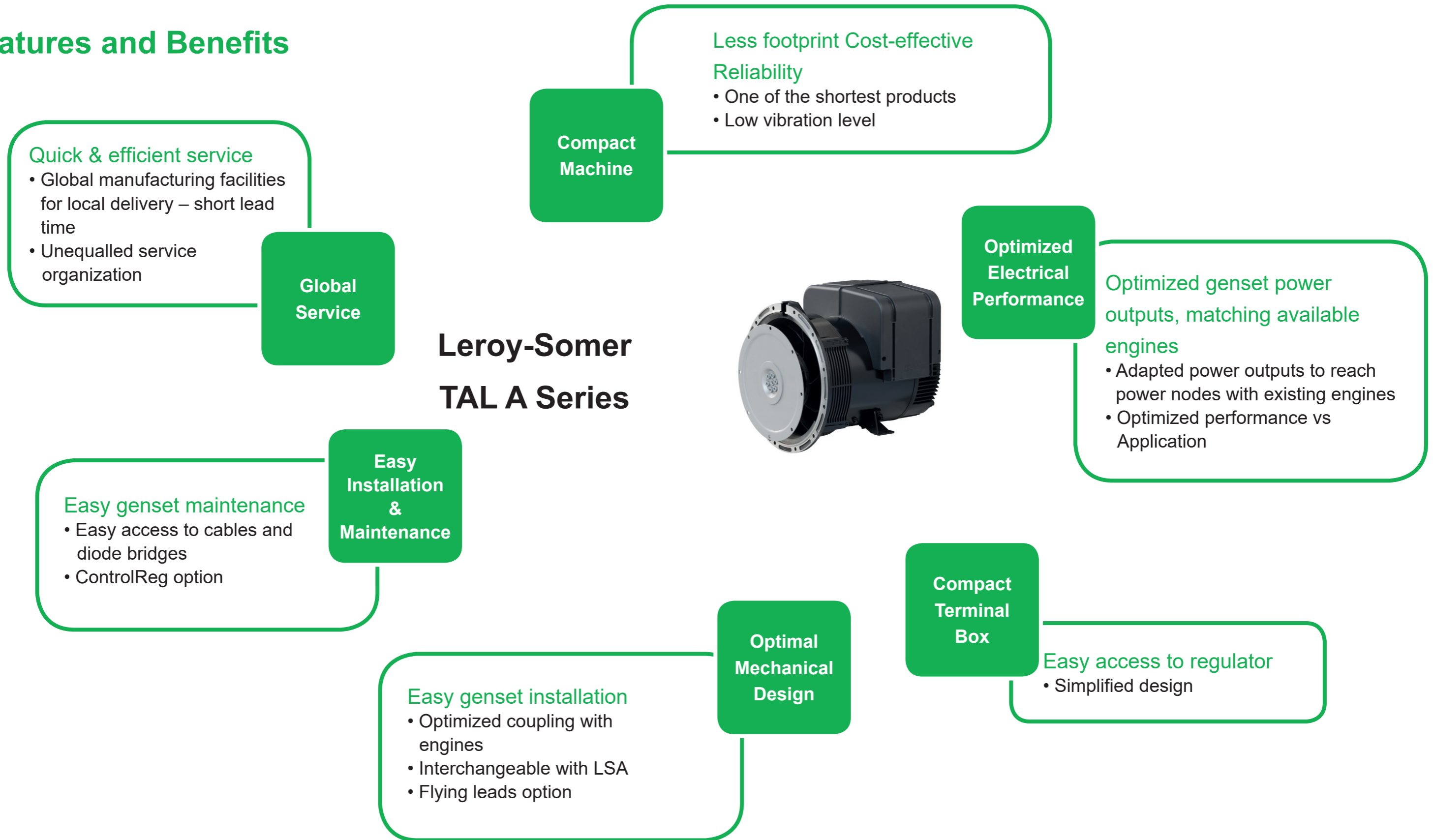

## Low Voltage Alternators - 4 pole

### TAL A40 - TAL A42 - TAL A44

#### Adapted to needs

The TAL alternator range is designed to meet the specific needs of telecommunications, commercial & industrial markets, as well as prime and stand-by power applications.

#### Compliance with internationally recognized standards

4 Pole Alternators are in compliance to the main international standards and regulations: -IEC 60034, NEMA MG 1.32-33, BS 5000 Part 99, VDE 0530, ISO 8528/3, UL 1446, UL 1004 on request and depending on voltages, marine regulations, etc. It can be integrated into a CE marked generator.

Alternators are designed, manufactured and marketed in an ISO 9001 and ISO14001 environments.

#### Electrical design

- Class H insulation
- Low voltage winding
- 4-terminal plate
- Optimized performance

#### Robust design

- Compact and rugged assembly to withstand engine vibrations
- Steel frame
- Aluminum flanges and shields
- Single-bearing design to be suitable with most diesel engines
- Sealed for life bearing
- Direction of rotation: clockwise

#### Excitation and regulation system suited to the application

	Excitation system				Regulation options		
	AVR	SHUNT	AREP+ (option)	PMG (Option Except TAL A40)	UL <sub>OCUS</sub>	Remote voltage potentiometer	C.T. for paralleling
Three-phase 6-wire	R120	Standard					
	R150	Option				√	
	R180		Standard	Standard		√	√
	D350	Option	Option	Option	√	√	√
Three-phase 12-wire*	R120	Standard					
	R250	Option Except TAL A40/42			√	√	
	R180		Standard	Standard		√	√
Single-phase	D350	Option	Option	Option	√	√	√
	R121	Standard				√	
	R250	Option			√	√	

√ : Possible option

#### Compact terminal box

- Easy access to AVR and terminals

#### Environment and protection

- The alternators are IP 23
- Standard winding protection for non-harsh environment with relative humidity ≤ 95%

#### Available options

- AREP+ & PMG (PMG suitable for TAL A42 and above)
- 12-lead (12-lead is standard option for TAL-A40 series)
- Customized painting
- Space heater
- Droop kit for alternator paralleling (AVR upgrade to R150)
- CE mark
- Stator sensors (TAL A44 only)
- Measuring/Protection CT (TAL A44 only, please consult Leroy Somer for CT type)
- Voltage trimmer (AVR upgrade to R150)
- Winding protection for harsh environments and relative humidity greater than 95% (system 2 - 4): de-rating ratio according to 3%



## Low Voltage Alternators - 4 pole

### TAL A40 - Three-phase 13 to 25 kVA - 50 Hz / 15 to 30 kVA - 60 Hz

#### General characteristics - 6 & 12-wire

Insulation class	H	Excitation system 6 wires	SHUNT	AREP+
Winding pitch	2/3 (wind.6S - 6-wire / wind.6 -12-wire)	AVR type	R120	R180
Number of wires	6 or 12	Excitation system 12 wires	SHUNT	AREP+
Protection	IP 23	AVR type	R120	R180
Altitude	≤ 1000 m	Voltage regulation (*)		± 1 %
Overspeed	2250 R.P.M.	Total Harmonic distortion THD (**) in no-load		< 3.5 %
Air flow 50 Hz (m³/s)	0.08	Total Harmonic distortion THD (**) in linear load		< 5 %
Air flow 60 Hz (m³/s)	0.10	Waveform: NEMA = TIF (**)		< 50
AREP+ Short-circuit current = 2.7 In: 5 seconds (*)		Waveform : I.E.C. : THF (**)		< 2%

\*D350: 2.7In 10 seconds

(\*) Steady state (\*\*) between phases

#### Ratings 50 Hz - 1500 R.P.M. - 6 & 12-wire

kVA / kW - P.F. = 0.8																	
Duty / T° C	Continuous / 40 °C				Continuous / 40 °C				Stand-by / 40 °C				Stand-by / 27 °C				
Class / T° K	H:125K				F:105K				H:150K				H:163K				
Phase	3ph.		1ph.		3ph.		1ph.		3ph.		1ph.		3ph.		1ph.		
Y	380V	400V	415V		380V	400V	415V		380V	400V	415V		380V	400V	415V		
Δ	220V	230V	240V		220V	230V	240V		220V	230V	240V		220V	230V	240V		
YY	190V	200V	208V		190V	200V	208V		190V	200V	208V		190V	200V	208V		
ΔΔ	230V				230V				230V				230V				
TAL A40 C	kVA	13	13	13	7	12	12	12	6	13.5	13.5	13.5	7.5	14	14	14	8
	kW	10.4	10.4	10.4	5.6	9.6	9.6	9.6	4.8	10.8	10.8	10.8	6.0	11.2	11.2	11.2	6.4
TAL A40 D	kVA	15	15	15	9	13.5	13.5	13.5	8	15.8	15.8	15.8	9.5	16.5	16.5	16.5	10.3
	kW	12.0	12.0	12.0	7.2	10.8	10.8	10.8	6.4	12.6	12.6	12.6	7.6	13.2	13.2	13.2	8.2
TAL A40 E	kVA	17.5	17.5	17.5	10.5	16	16	16	9.5	18.4	18.4	18.4	11	19.3	19.3	19.3	12
	kW	14.0	14.0	14.0	8.4	12.8	12.8	12.8	7.6	14.7	14.7	14.7	8.8	15.4	15.4	15.4	9.6
TAL A40 F	kVA	20	20	20	12	18	18	18	11	21	21	21	12.5	22	22	22	13.4
	kW	16.0	16.0	16.0	9.6	14.4	14.4	14.4	8.8	16.8	16.8	16.8	10.0	17.6	17.6	17.6	10.8
TAL A40 G	kVA	25	25	25	15	22.5	22.5	22.5	13.5	26	26	26	16	27.5	27.5	27.5	16.6
	kW	20.0	20.0	20.0	12.0	18.0	18.0	18.0	10.8	20.8	20.8	20.8	12.8	22.0	22.0	22.0	13.3

#### Ratings 60 Hz - 1800 R.P.M. - 6 & 12-wire

kVA / kW - P.F. = 0.8																					
Duty / T° C	Continuous / 40 °C				Continuous / 40 °C				Stand-by / 40 °C				Stand-by / 27 °C								
Class / T° K	H:125K				F:105K				H:150K				H:163K								
Phase	3ph.		1ph.		3ph.		1ph.		3ph.		1ph.		3ph.		1ph.						
Y	380V	416V	440V	480V		380V	416V	440V	480V		380V	416V	440V	480V		380V	416V	440V	480V		
Δ	220V	240V	254V	277V		220V	240V	254V	277V		220V	240V	254V	277V		220V	240V	254V	277V		
YY	190V	208V	220V	240V		190V	208V	220V	240V		190V	208V	220V	240V		190V	208V	220V	240V		
ΔΔ	240V				240V				240V				240V								
TAL A40 C	kVA	12	13.4	14	15.5	9	11	12	13	14	8	13	14	15	16	9.5	13.5	15	15.5	17	10
	kW	9.6	10.7	11.2	12.4	7.2	8.8	9.6	10.4	11.2	6.4	10.4	11.2	12.0	12.8	7.6	10.8	12.0	12.4	13.6	8.0
TAL A40 D	kVA	14	15.3	16	18	11.6	13	14	14.5	16.5	10.4	15	16	17	19	12	15.8	16.8	17.8	20	13
	kW	11.2	12.2	12.8	14.4	9.3	10.4	11.2	11.6	13.2	8.3	12.0	12.8	13.6	15.2	9.6	12.6	13.4	14.2	16.0	10.4
TAL A40 E	kVA	17	17.9	19	21	13	15	16	17	19	12	18	19	20	22	14	18.5	19.6	20.8	23	14
	kW	13.6	14.3	15.2	16.8	10.4	12.0	12.8	13.6	15.2	9.6	14.4	15.2	16.0	17.6	11.2	14.8	15.7	16.6	18.4	11.2
TAL A40 F	kVA	19	20.5	21.5	24	14	17	18.5	19.5	22	12.5	20	21.5	23	25	14.6	21	22.5	24	26	15
	kW	15.2	16.4	17.2	19.2	11.2	13.6	14.8	15.6	17.6	10.0	16.0	17.2	18.4	20.0	11.7	16.8	18.0	19.2	20.8	12.0
TAL A40 G	kVA	24	26	27	30	17	21	23.5	24	27	15.4	25	27	28.5	31.5	18	26	28.5	30	33	19
	kW	19.2	20.8	21.6	24.0	13.6	16.8	18.8	19.2	21.6	12.3	20.0	21.6	22.8	25.2	14.4	20.8	22.8	24.0	26.4	15.2

## Low Voltage Alternators - 4 pole

TAL A40 - Three-phase 13 to 25 kVA - 50 Hz / 15 to 30 kVA - 60 Hz

Efficiencies 400 V - 50 Hz (— P.F.: 0.8) (..... P.F.: 1) - 6 & 12-wire

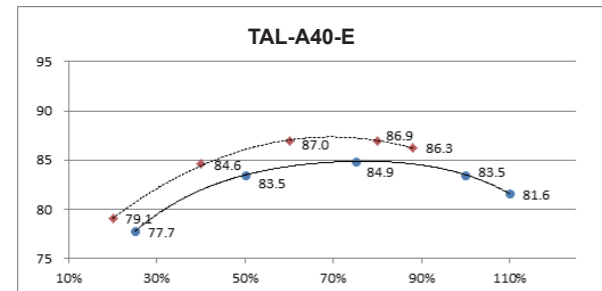
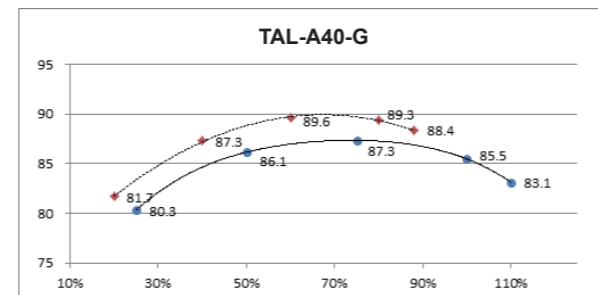
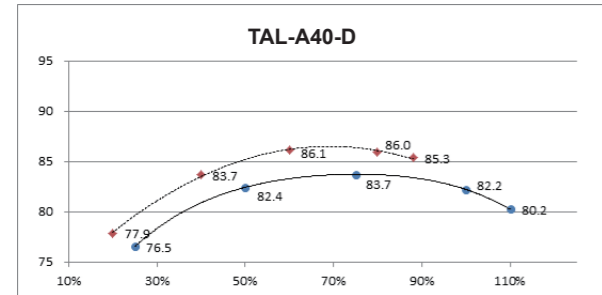
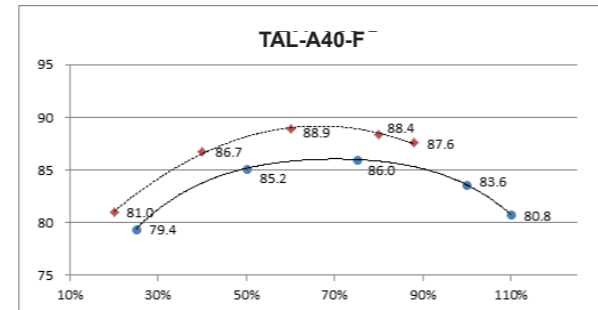
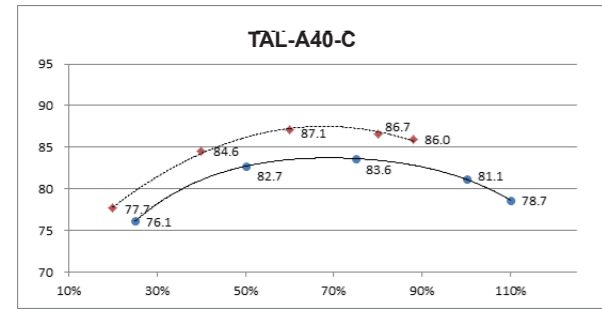

Reactances (%). Time constants (ms) - Class H / 400 V - 6 & 12-wire

	TAL A40 C	TAL A40 D	TAL A40 E	TAL A40 F	TAL A40 G
<b>Kcc</b> Short-circuit ratio	0.55	0.55	0.54	0.45	0.45
<b>Xd</b> Direct-axis synchro. reactance unsaturated	217	209	222	251	256
<b>Xq</b> Quadrature-axis synchro. reactance unsaturated	130	125	133	151	153
<b>T'do</b> No-load transient time constant	789	826	850	873	914
<b>X'd</b> Direct-axis transient reactance saturated	19.1	17.7	18.2	19.2	19.1
<b>T'd</b> Short-circuit transient time constant	74	74	74	74	74
<b>X''d</b> Direct-axis subtransient reactance saturated	9.5	8.8	9.0	9.5	9.5
<b>T''d</b> Subtransient time constant	7.0	7.0	7.0	7.0	7.0
<b>X''q</b> Quadrature-axis subtransient reactance saturated	20.0	18.6	19.0	20.1	20.0
<b>Xo</b> Zero sequence reactance	0.13	0.13	0.14	0.15	0.16
<b>X2</b> Negative sequence reactance saturated	14.8	13.7	14.0	14.8	14.7
<b>Ta</b> Armature time constant	11	11	11	11	11

  

Other class H / 400 V data		TAL A40 C	TAL A40 D	TAL A40 E	TAL A40 F	TAL A40 G
ms	Response time ( $\Delta U = 20\%$ )	500	500	500	500	500
W	No-load losses	483	546	578	630	704
W	Heat dissipation	2424	2599	2766	3139	3392

## Low Voltage Alternators - 4 pole

TAL A40 - Three-phase 13 to 25 kVA - 50 Hz / 15 to 30 kVA - 60 Hz

Transient voltage variation 400V - 50 Hz

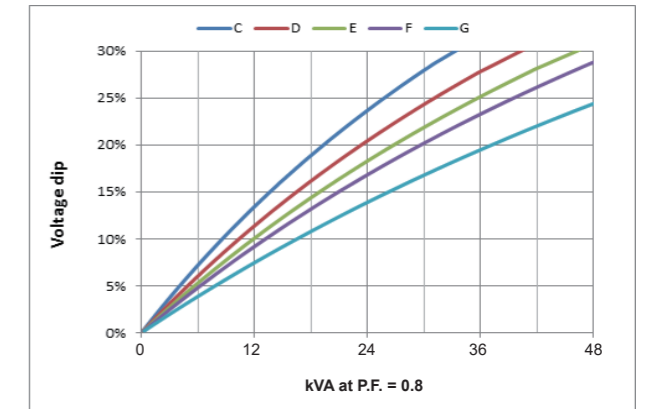
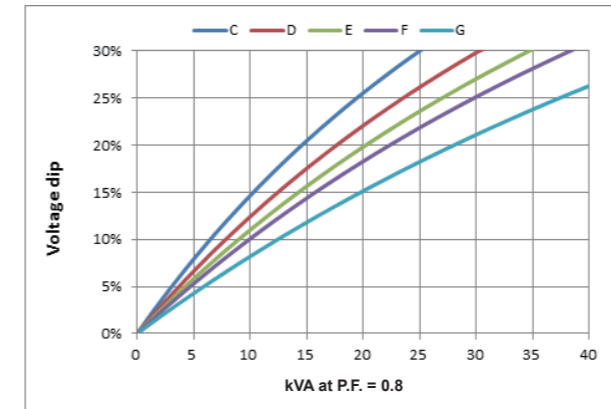

Phase loading (SHUNT/AREP+) - kVA at P.F. = 0.8

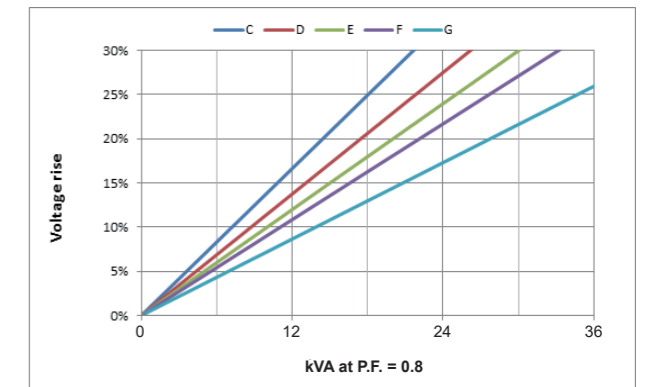
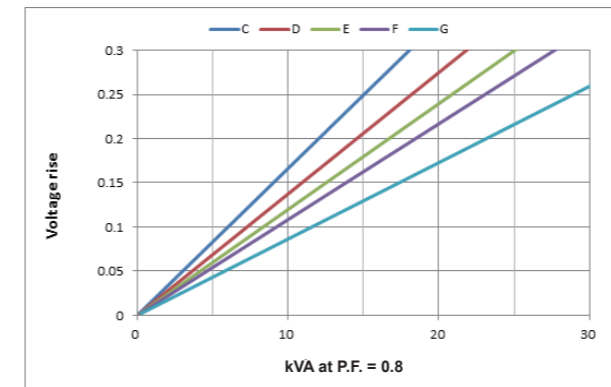

Load shedding (SHUNT/AREP+) - kVA at P.F. = 0.8

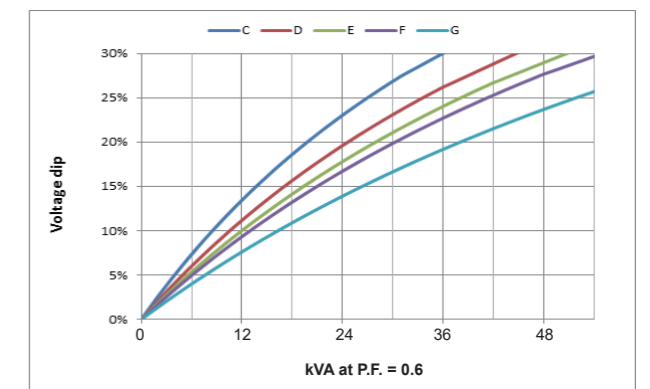
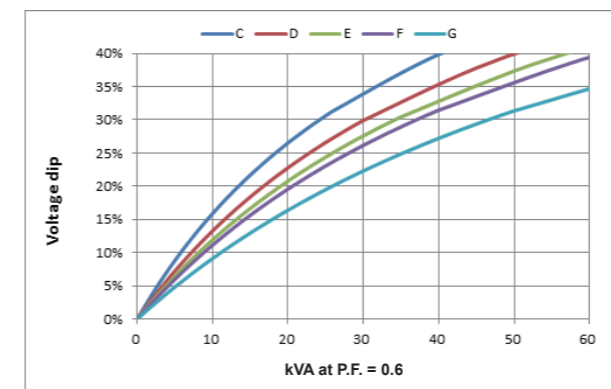

Motor starting (SHUNT/AREP+) - locked rotor kVA at P.F. = 0.6

- 1) For a starting P.F. other than 0.6, the starting kVA must be multiplied by  $K = \text{Sine P.F.} / 0.8$
- 2) For voltages other than 400V (Y), 230V ( $\Delta$ ) at 50 Hz, then kVA must be multiplied by  $(400/U)^2$  or  $(230/U)^2$ .



## Low Voltage Alternators - 4 pole

TAL A40 - Three-phase 13 to 25 kVA - 50 Hz / 15 to 30 kVA - 60 Hz

Efficiencies 480 V - 60 Hz (— P.F.: 0.8) (..... P.F.: 1) - 6 & 12-wire

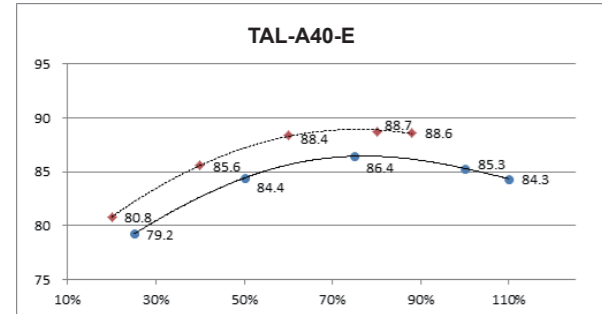
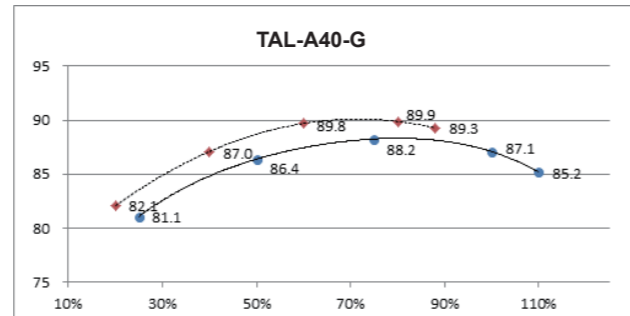
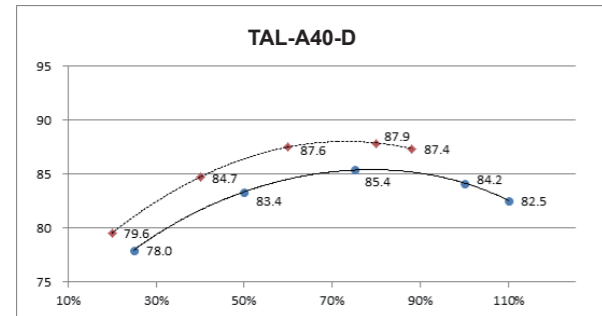
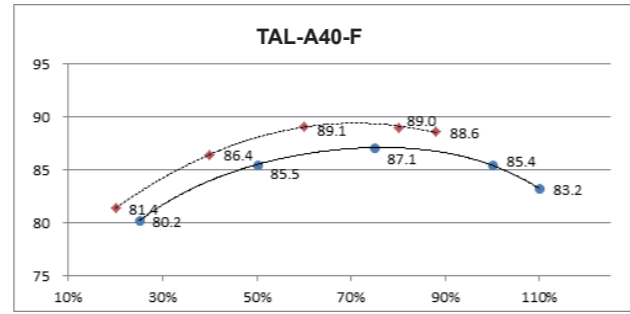
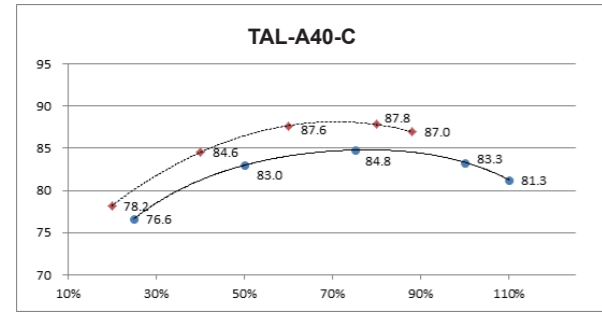

Reactances (%). Time constants (ms) - Class H / 480 V - 6 & 12-wire

	TAL A40 C	TAL A40 D	TAL A40 E	TAL A40 F	TAL A40 G
<b>Kcc</b> Short-circuit ratio	0.55	0.55	0.54	0.45	0.45
<b>Xd</b> Direct-axis synchro. reactance unsaturated	217	209	222	251	256
<b>Xq</b> Quadrature-axis synchro. reactance unsaturated	130	125	133	151	153
<b>T'do</b> No-load transient time constant	789	826	850	873	914
<b>X'd</b> Direct-axis transient reactance saturated	19.1	17.7	18.2	19.2	19.1
<b>T'd</b> Short-circuit transient time constant	74	74	74	74	74
<b>X''d</b> Direct-axis subtransient reactance saturated	9.5	8.8	9.0	9.5	9.5
<b>T''d</b> Subtransient time constant	7.0	7.0	7.0	7.0	7.0
<b>X''q</b> Quadrature-axis subtransient reactance saturated	20.0	18.6	19.0	20.1	20.0
<b>Xo</b> Zero sequence reactance	0.13	0.13	0.14	0.15	0.16
<b>X2</b> Negative sequence reactance saturated	14.8	13.7	14.0	14.8	14.7
<b>Ta</b> Armature time constant	11	11	11	11	11

  

Other class H / 480 V data	TAL A40 C	TAL A40 D	TAL A40 E	TAL A40 F	TAL A40 G
<b>ms</b> Response time ( $\Delta U = 20\%$ )	500	500	500	500	500
<b>W</b> No-load losses	696	786	832	907	1013
<b>W</b> Heat dissipation	2486	2702	2895	3282	3555

## Low Voltage Alternators - 4 pole

TAL A40 - Three-phase 13 to 25 kVA - 50 Hz / 15 to 30 kVA - 60 Hz

Transient voltage variation 480V - 60 Hz

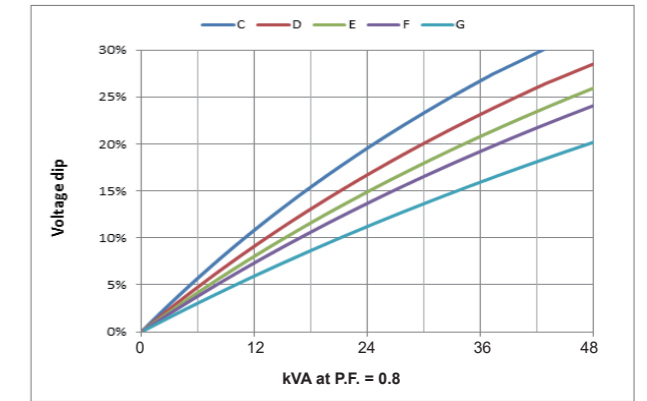
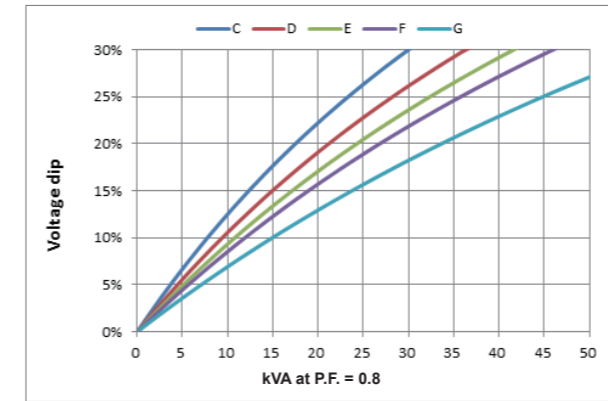

Phase loading (SHUNT/AREP+) - kVA at P.F. = 0.8

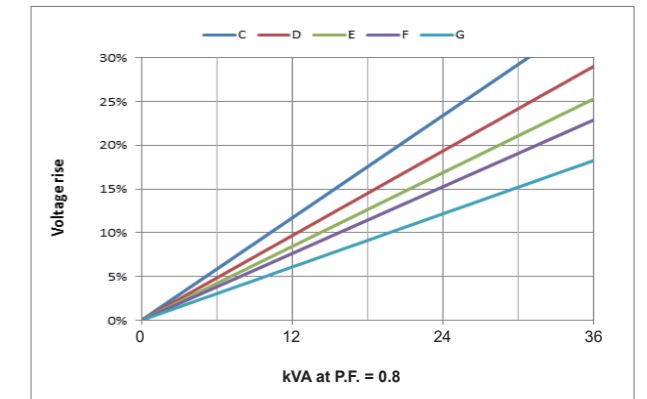
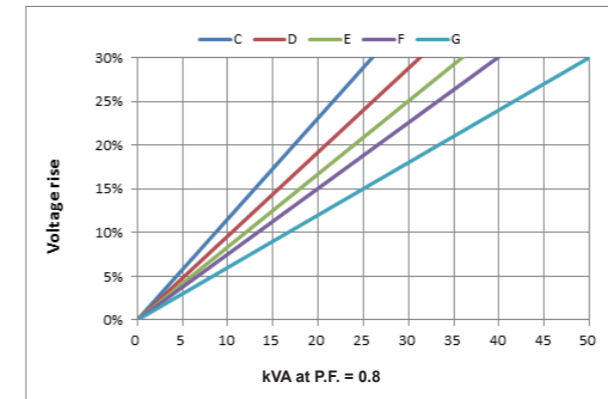

Load shedding (SHUNT/AREP+) - kVA at P.F. = 0.8

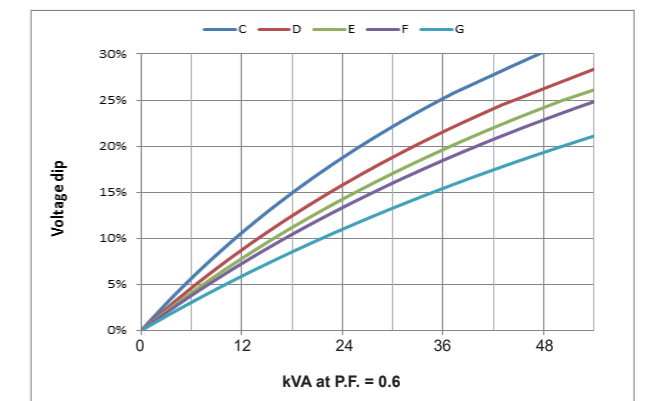
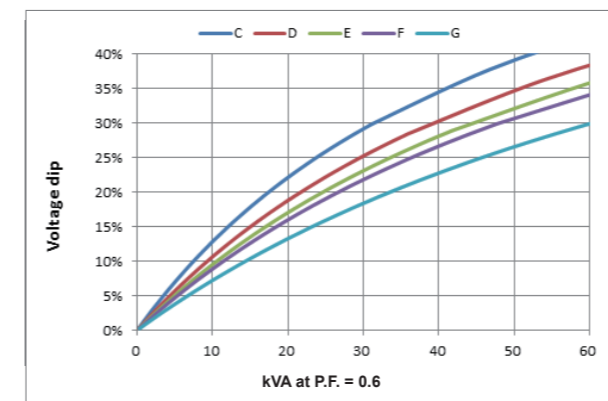

Motor starting (SHUNT/AREP+) - locked rotor kVA at P.F. = 0.6

- 1) For a starting P.F. other than 0.6, the starting kVA must be multiplied by  $K = \text{Sine P.F.} / 0.8$
- 2) For voltages other than 480V (Y), 277V ( $\Delta$ ), 240V (YY) at 60 Hz, then kVA must be multiplied by  $(480/U)^2$  or  $(277/U)^2$  or  $(240/U)^2$ .

## Low Voltage Alternators - 4 pole

**TAL A40 - Three-phase** 13 to 25 kVA - 50 Hz / 15 to 30 kVA - 60 Hz

### Single bearing general arrangement - 4, 6 & 12-wire

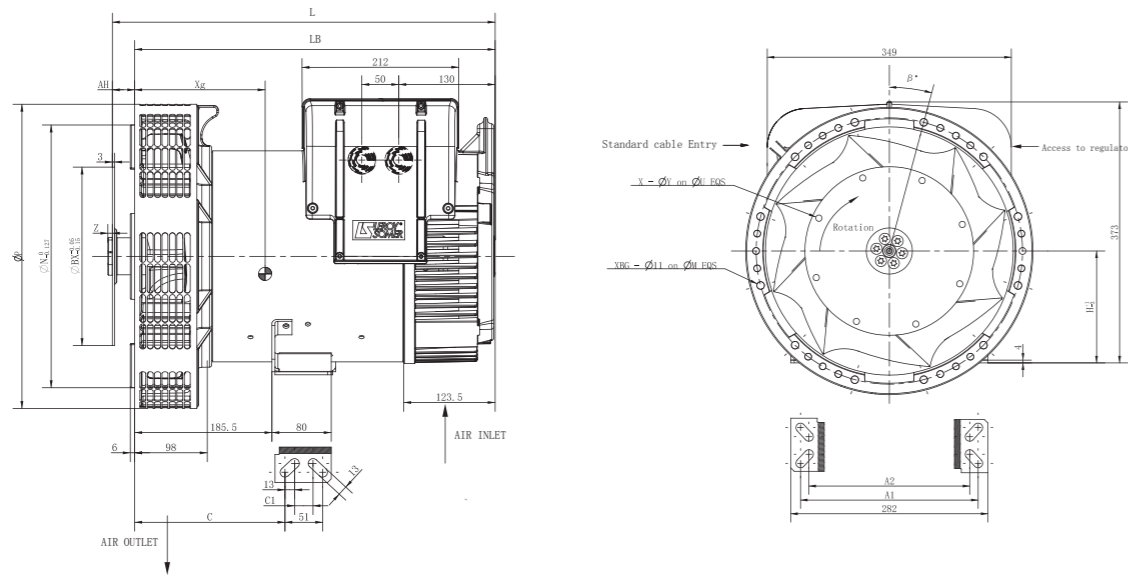

Dimensions (mm) and weight				
Type	L maxi	LB	Xg	Weight (kg)
TAL A40 C	LB+AH	407	186	73
TAL A40 D	LB+AH	407	196	80
TAL A40 E	LB+AH	437	204	87
TAL A40 F	LB+AH	437	221	92
TAL A40 G	LB+AH	487	226	108

Shaft height (mm)			Coupling		
	Standard	Option	Flange	3	4
H	160	180	Flex plate		
	Feet length		11 1/2	x	-
C	203	238	10	x	x
C1	25	22	8	x	x
A1	254	279	7 1/2	-	x
A2	230	-	6 1/2	-	x

Flange (mm)					
S.A.E.	P	N	M	XBG	β°
4	411	361.95	381	12	15°
3	450	409.58	428.62	12	15°

Flex plate (mm)						
S.A.E.	BX	U	X	Y	AH	Z
6 1/2	215.9	200.02	6	9	30.2	6
7 1/2	241.3	222.25	8	9	30.2	6
8	263.52	244.48	6	11	62	0
10	314.32	295.28	8	11	53.8	0
11 1/2	352.42	333.38	8	11	39.6	0

### Torsional analysis data

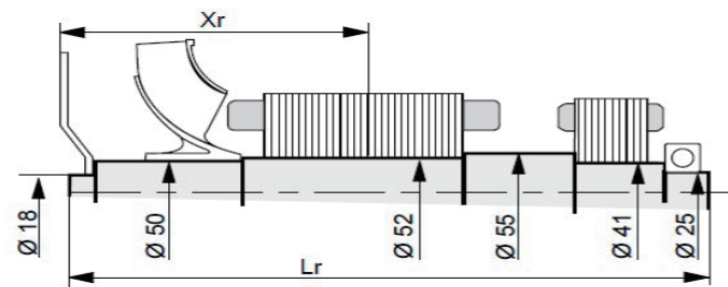

Centre of gravity: Xr (mm), Rotor length: Lr (mm), Weight: M (kg), Moment of inertia: J (kgm <sup>2</sup> ): (4J = MD <sup>2</sup> )																				
Type	Flex plate S.A.E. 6 1/2				Flex plate S.A.E. 7 1/2				Flex Plate SAE 8				Flex Plate SAE 10				Flex Plate SAE 11 1/2			
	Xr	Lr	M	J	Xr	Lr	M	J	Xr	Lr	M	J	Xr	Lr	M	J	Xr	Lr	M	J
TAL A40 C	211.43	428	25.6	0.0795	211.43	428	25.76	0.0818	243.24	428	26.06	0.0863	238.04	428	26.56	0.098	220.85	428	27.06	0.1096
TAL A40 D	221.43	428	28.01	0.0883	221.43	428	28.17	0.0906	253.24	428	28.47	0.0951	248.04	428	28.97	0.1068	230.85	428	29.47	0.1184
TAL A40 E	228.94	458	30.38	0.0952	228.94	458	30.54	0.0975	260.74	458	30.84	0.102	255.55	458	31.34	0.1137	238.35	458	31.84	0.1253
TAL A40 F	236.44	458	32.29	0.1021	236.44	458	32.45	0.1044	268.24	458	32.75	0.1089	263.05	458	33.25	0.1206	245.85	458	33.75	0.1322
TAL A40 G	251.45	508	37.03	0.1164	251.45	508	37.19	0.1187	283.25	508	37.49	0.1232	278.06	508	37.99	0.1349	260.86	508	38.49	0.1465

**NOTE** : Dimensions are for information only and may be subject to modifications. Contractual 2D/3D drawings can be downloaded from the Leroy-Somer site. The torsional analysis of the transmission is imperative. All values are available upon request.

## Low Voltage Alternators - 4 pole

**TAL A40 - S Dedicated single-phase** 10.5 to 16 kVA - 50 Hz / 11.5 to 17.5 kVA - 60 Hz

### General characteristics

Insulation class	H	Excitation system	SHUNT
Winding pitch	2/3 (wind. M)	AVR type	R121
Number of wires	4	Voltage regulation (*)	± 1 %
Protection	IP 23	Total Harmonic Distortion THD (**) in no-load	< 3.5 %
Altitude	≤ 1000 m	Total Harmonic Distortion THD (**) in linear load	< 5 %
Overspeed	2250 R.P.M.	Waveform: NEMA = TIF (**)	< 100
Air flow (m <sup>3</sup> /s)	50 Hz: 0.06 - 60 Hz: 0.07	Waveform: I.E.C. = THF (**)	< 2 %

(\*) Steady state (\*\*) Total harmonic distortion between phases, no-load or on-load (non-distorting)

### Ratings / Efficiencies 50 Hz - 1500 R.P.M.

kVA / kW - P.F. = 1(*)						
Duty / T° C	Continuous / 40 °C	Continuous / 40 °C	Stand-by / 40 °C	Stand-by / 27 °C		
Class / T° K	H / 125° K	F / 105° K	H / 150° K	H / 163° K		
Serie (SE)	230 V	η %	230 V	230 V	230V	η %
Parallel (PA)	115 V	η %	115 V	115 V	115 V	η %
<b>TAL A40 C-S</b>	10.5	82.4	9.5	11	11.5	81.2
<b>TAL A40 C1-S</b>	12	84.5	11	12.5	13	83.7
<b>TAL A40 D-S</b>	13	85.4	12	14	14.5	84.7
<b>TAL A40 E-S</b>	14.5	86.3	13	15.5	16	85.6
<b>TAL A40 F-S</b>	16	87.3	14.5	17	17.5	86.7

(\*) For P.F. 0.8: derating 15%

### Ratings / Efficiencies 60 Hz - 1800 R.P.M.

kVA / kW - P.F. = 1(*)						
Duty / T° C	Continuous / 40 °C	Continuous / 40 °C	Stand-by / 40 °C	Stand-by / 27 °C		
Class / T° K	H / 125° K	F / 105° K	H / 150° K	H / 163° K		
Serie (SE)	240 V	η %	240 V	240 V	240V	η %
Parallel (PA)	120 V	η %	120 V	120 V	120 V	η %
<b>TAL A40 C-S</b>	11.5	82.6	10.5	12	12.5	81.7
<b>TAL A40 C1-S</b>	13.5	84.2	12.5	14.5	15	83.4
<b>TAL A40 D-S</b>	14.5	85	13	15.5	16	84.3
<b>TAL A40 E-S</b>	16	85.9	14.5	17	17.5	85.3
<b>TAL A40 F-S</b>	17.5	86.9	16	18.5	19.5	86.3

(\*) For P.F. 0.8: derating 15%

### Starting motor 230V - 50Hz

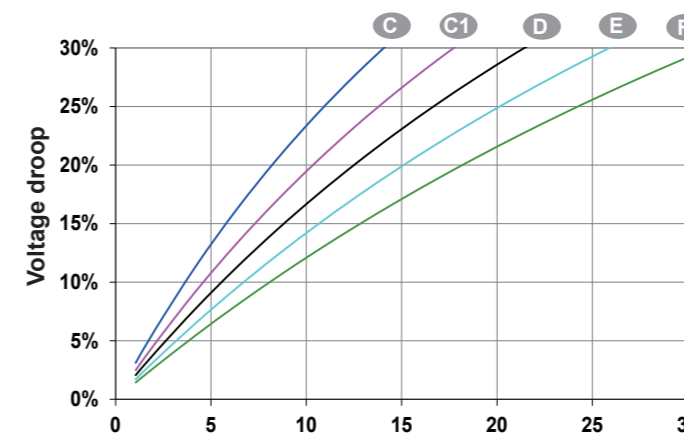

### Starting motor 240V - 60Hz

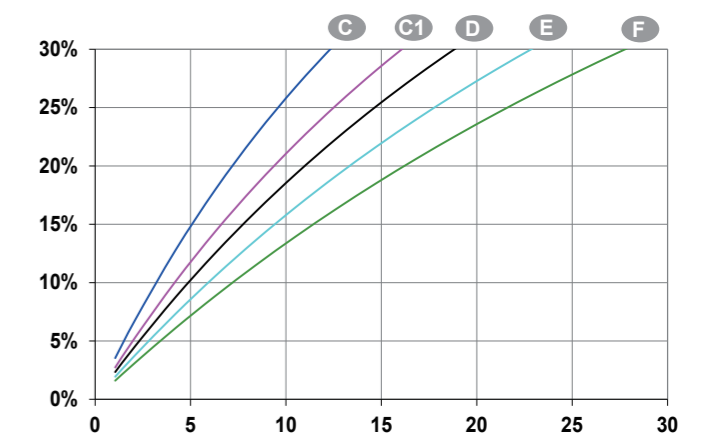

Locked rotor kVA at PF : 0.9

## Low Voltage Alternators - 4 pole

### TAL A40 - S Single-phase

#### Single bearing general arrangement

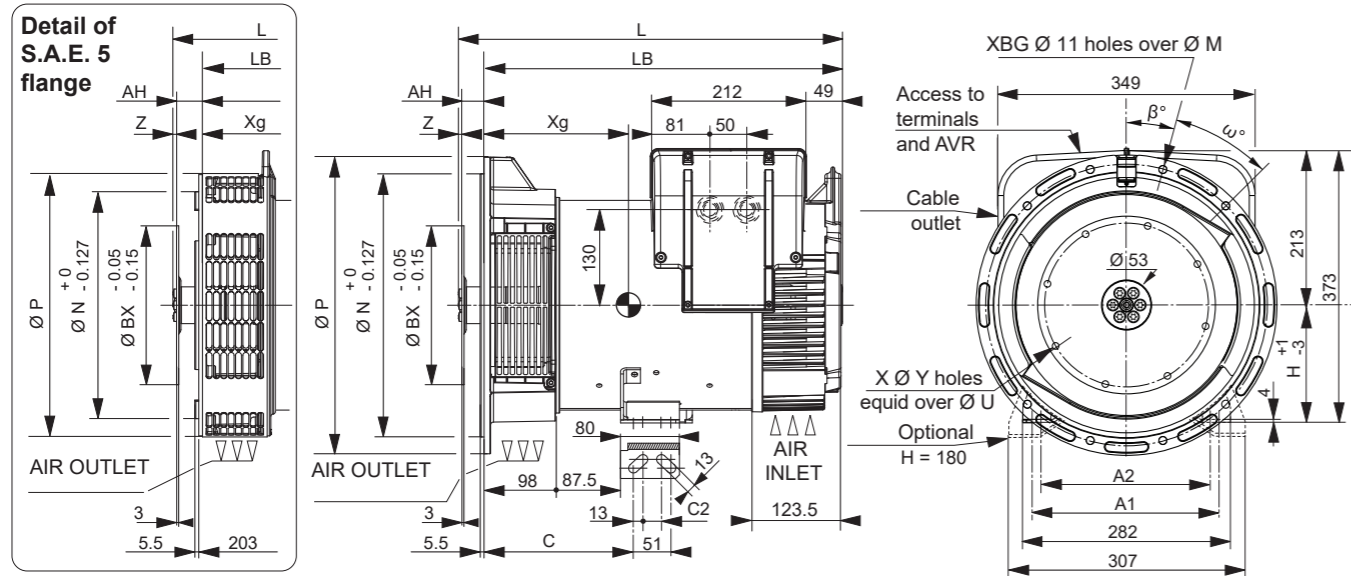

Dimensions (mm) and weight				
Type	L maxi	LB	Xg	Weight (kg)
TAL A40 C-S	469	407	186	73
TAL A40 C1-S	469	407	196	80
TAL A40 D-S	499	437	204	87
TAL A40 E-S	499	437	221	92
TAL A40 F-S	519	457	221	102

Shaft height (mm)			Coupling			
	Standard	Option	Flange	3	4	5
H	160	180	Flex plate			
	Feet length		11 1/2	x	-	-
C	203	238	10	x	x	-
C2	25	22	8	x	x	-
A1	254	279	7 1/2	-	x	x
A2	230	-	6 1/2	-	x	x

Lmaxi = LB + AH

Flange (mm)						
S.A.E.	P	N	M	XBG	β°	ω°
5	358	314.32	333.38	8	22°30'	45°
4	408	361.95	381	8*	15°	30°
3	460	409.58	428.62	8*	15°	30°
-	-	-	-	-	-	-

\*Four lateral holes removal on S.A.E. 3 and 4

Flex plate (mm)						
S.A.E.	BX	U	X	Y	AH	Z
11 1/2	352.42	333.38	8	11	39.6	0
10	314.32	295.28	8	11	53.8	0
8	263.52	244.48	6	11	62	0
7 1/2	241.3	222.25	8	9	30.2	6
6 1/2	215.9	200.02	6	9	30.2	6

#### Torsional data

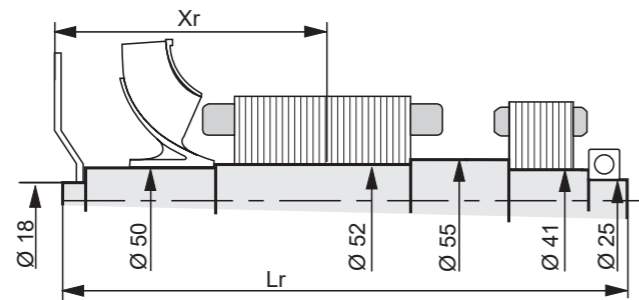

Centre of gravity: Xr (mm), Rotor length: Lr (mm), Weight: M (kg), Moment of inertia: J (kgm <sup>2</sup> ): (4J = MD <sup>2</sup> )																
Flex plate	S.A.E. 6 1/2				S.A.E. 7 1/2				S.A.E. 8				S.A.E. 10			
	Type	Xr	Lr	M	J	Xr	Lr	M	J	Xr	Lr	M	J	Xr	Lr	M
TAL A40 C-S	211.7	428	25.5	0.078	211.7	428	25.7	0.080	243.5	428	26	0.085	238.3	428	26.5	0.096
TAL A40 C1-S	221.7	428	27.9	0.087	221.7	428	28.1	0.089	253.5	428	28.4	0.094	248.3	428	28.9	0.105
TAL A40 D-S	229.2	458	30.3	0.094	229.2	458	30.5	0.096	261	458	30.8	0.100	255.8	458	31.3	0.112
TAL A40 E-S	236.7	458	32.2	0.100	236.7	458	32.4	0.103	268.5	458	32.7	0.107	263.3	458	33.2	0.119
TAL A40 F-S	246.7	478	35.3	0.110	246.7	478	35.4	0.113	278.5	478	35.7	0.117	273.3	478	36.2	0.129

NOTE : Dimensions are for information only and may be subject to modifications. The torsional analysis of the transmission is imperative. All values are available upon request.

## Low Voltage Alternators - 4 pole

### TAL A42 - Three-phase 30 to 63 kVA - 50 Hz / 36 to 75.6 kVA - 60 Hz

#### General characteristics - 6 & 12-wire

Insulation class	H	Excitation system 6 wires	SHUNT	AREP+/PMG
Winding pitch	2/3 (wind.6S - 6-wire / wind.6 -12-wire)	AVR type	R120	R180
Number of wires	6 or 12	Excitation system 12 wires	SHUNT	AREP+/PMG
Protection	IP 23	AVR type	R120	R180
Altitude	≤ 1000 m	Voltage regulation (*)	± 1 %	
Overspeed	2250 R.P.M.	Total Harmonic distortion THD (**) in no-load	< 3.5 %	
Air flow 50 Hz (m <sup>3</sup> /s)	0.12	Total Harmonic distortion THD (**) in linear load	< 5 %	
Air flow 60 Hz (m <sup>3</sup> /s)	0.15	Waveform: NEMA = TIF (**)	< 50	
AREP+ Short-circuit current = 2.7 In: 5 seconds (*)		Waveform : I.E.C. : THF (**)	< 2%	

\*D350: 2.7In 10 seconds

(\*) Steady state (\*\*) Total harmonic distortion between phases, no-load or on-load (non-distorting)

#### Ratings 50 Hz - 1500 R.P.M. - 6 & 12-wire

kVA / kW - P.F. = 0.8																	
Duty / T° C	Continuous / 40 °C				Continuous / 40 °C				Stand-by / 40 °C				Stand-by / 27 °C				
Class / T° K	H:125K		F:105K		H:150K		H:163K		H:125K		F:105K		H:150K		H:163K		
Phase	3ph.		1ph.		3ph.		1ph.		3ph.		1ph.		3ph.		1ph.		
Y	380V	400V	415V		380V	400V	415V		380V	400V	415V		380V	400V	415V		
Δ	220V	230V	240V		220V	230V	240V		220V	230V	240V		220V	230V	240V		
YY	190V	200V	208V		190V	200V	208V		190V	200V	208V		190V	200V	208V		
ΔΔ					230V				230V				230V				
TAL A42 C	kVA	29	30	30	18	26	27	27	16	30	31.5	31.5	19	31	33	33	19.8
	kW	23.2	24.0	24.0	14.4	20.8	21.6	21.6	12.8	24.0	25.2	25.2	15.2	24.8	26.4	26.4	15.8
TAL A42 E	kVA	36	38	38	22.8	32.5	34.5	34	20.5	38	40	40	24	40	42	42	25.6
	kW	28.8	30.4	30.4	18.2	26.0	27.6	27.2	16.4	30.4	32.0	32.0	19.2	32.0	33.6	33.6	20.5
TAL A42 F	kVA	43	45	45	25	38.5	40.5	40.5	22.5	45	47	47	26	48	50	50	28
	kW	34.4	36.0	36.0	20.0	30.8	32.4	32.4	18.0	36.0	37.6	37.6	20.8	38.4	40.0	40.0	22.4
TAL A42 G	kVA	48	50	50	27	43	45	45	24	50	52.5	52.5	28	52	55	55	30
	kW	38.4	40.0	40.0	21.6	34.4	36.0	36.0	19.2	40.0	42.0	42.0	22.4	41.6	44.0	44.0	24.0
TAL A42 H	kVA	60	63	63	36	54	57	57	32.5	63	66	66	38	67	70	70	40
	kW	48.0	50.4	50.4	28.8	43.2	45.6	45.6	26.0	50.4	52.8	52.8	30.4	53.6	56.0	56.0	32.0

#### Ratings 60 Hz - 1800 R.P.M. - 6 & 12-wire

kVA / kW - P.F. = 0.8																					
Duty / T° C	Continuous / 40 °C				Continuous / 40 °C				Stand-by / 40 °C				Stand-by / 27 °C								
Class / T° K	H:125K		F:105K		H:150K		H:163K		H:125K		F:105K		H:150K		H:163K						
Phase	3ph.		1ph.		3ph.		1ph.		3ph.		1ph.		3ph.		1ph.						
Y	380V	416V	440V	480V		380V	416V	440V	480V		380V	416V	440V	480V		380V	416V	440V	480V		
Δ	220V	240V	254V	277V		220V	240V	254V	277V		220V	240V	254V	277V		220V	240V	254V	277V		
YY	190V	208V	220V	240V		190V	208V	220V	240V		190V	208V	220V	240V		190V	208V	220V	240V		
ΔΔ					240V				240V				240V								
TAL A42 C	kVA	28	31	32.5	36	21.5	25.5	28	29	32.5	19.4	30	32.5	34	38	22.6	31	34	36	39.5	23.5
	kW	22.4	24.8	26.0	28.8	17.2	20.4	22.4	23.2	26.0	15.5	24.0	26.0	27.2	30.4	18.1	24.8	27.2	28.8	31.6	18.8
TAL A42 E	kVA	36	39.5	41.4	45.5	25	32.5	35.5	37	41	23	38	41.5	43.5	48	26.4	39.5	43.5	45.5	50	27.7
	kW	28.8	31.6	33.1	36.4	20.0	26.0	28.4	29.6	32.8	18.4	30.4	33.2	34.8	38.4	21.1	31.6	34.8	36.4	40.0	22.2
TAL A42 F	kVA	43	46.5	49	54	28	38.5	42	44	49	25	45	48.5	51.5	56.5	29	47	51	54	59	31
	kW	34.4	37.2	39.2	43.2	22.4	30.8	33.6	35.2	39.2	20.0	36.0	38.8	41.2	45.2	23.2	37.6	40.8	43.2	47.2	24.8
TAL A42 G	kVA	47	52	54.5	60	30.5	43	47	49	54	27.5	50	54.5	57	63	32	52	57	60	66	33.6
	kW	37.6	41.6	43.6	48.0	24.4	34.4	37.6	39.2	43.2	22.0	40.0	43.6	45.6	50.4	25.6	41.6	45.6	48.0	52.8	26.9
TAL A42 H	kVA	60	65.5	68.5	75.6	39	54	59	62	68	35	63	68.5	72	79	41	66	72	75.5	83	43
	kW	48.0	52.4	54.8	60.5	31.2	43.2	47.2	49.6	54.4	28.0	50.4	54.8	57.6	63.2	32.8	52.8	57.6	60.4	66.4	34.4



## Low Voltage Alternators - 4 pole

TAL A42 - Three-phase 30 to 63 kVA - 50 Hz / 36 to 75.6 kVA - 60 Hz

Efficiencies 400 V - 50 Hz (— P.F.: 0.8) (..... P.F.: 1) - 6 & 12-wire

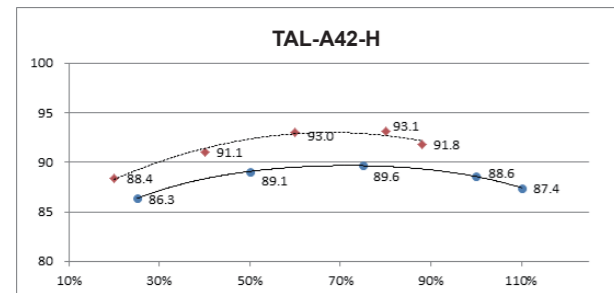
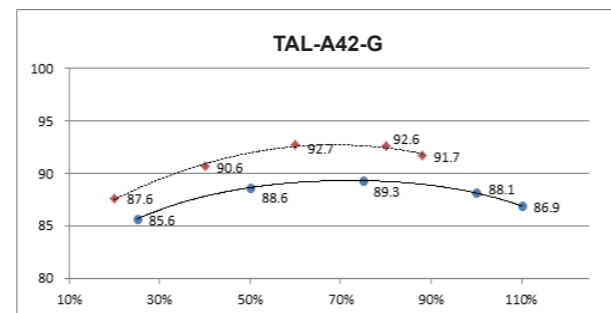
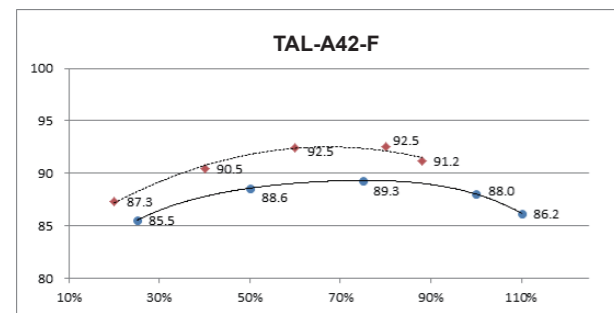
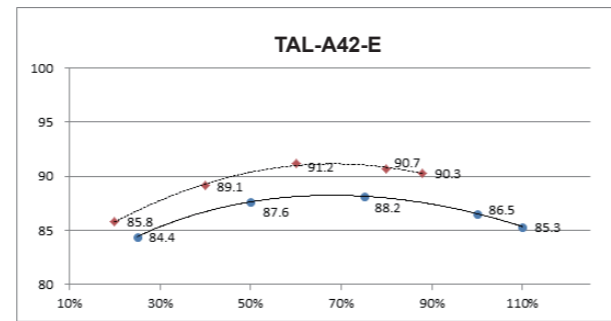
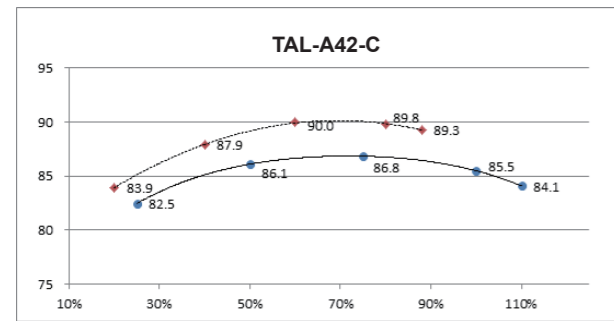

## Low Voltage Alternators - 4 pole

TAL A42 - Three-phase 30 to 63 kVA - 50 Hz / 36 to 75.6 kVA - 60 Hz

Transient voltage variation 400V - 50 Hz - 12-wire

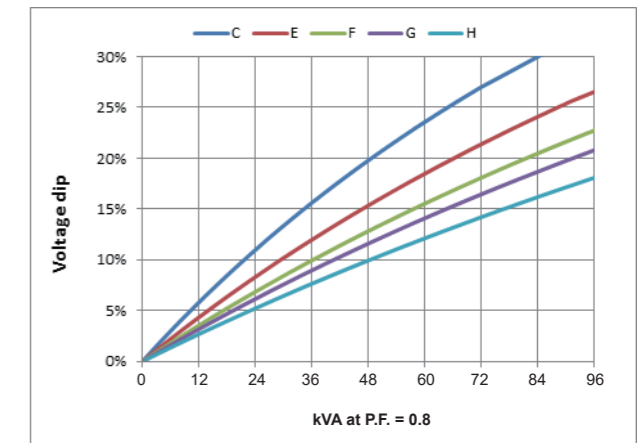
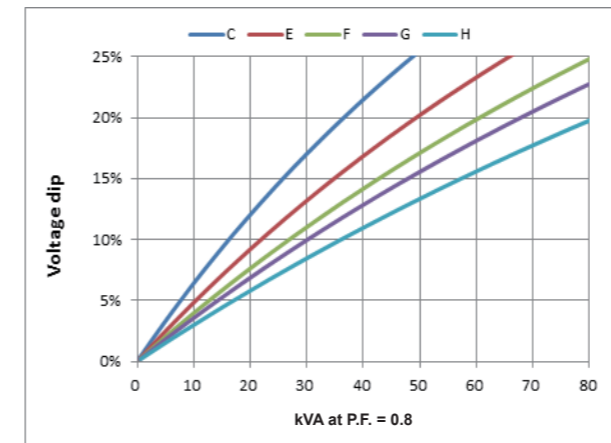

Phase loading (SHUNT/AREP+) - kVA at P.F. = 0.8

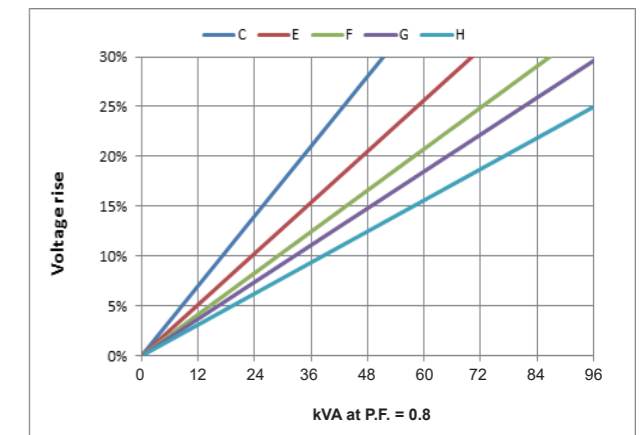
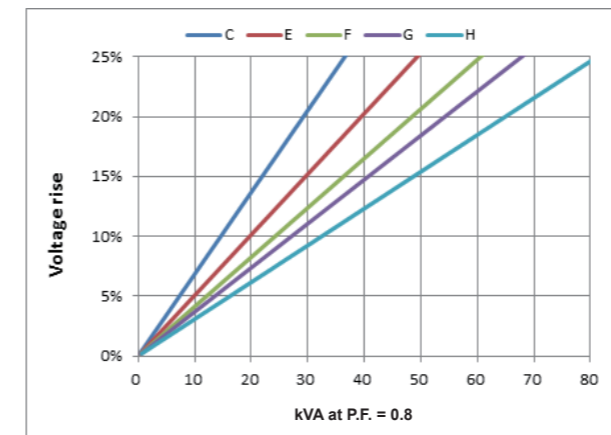

Reactances (%). Time constants (ms) - Class H / 400 V - 6 & 12-wire

	TAL A42 C	TAL A42 E	TAL A42 F	TAL A42 G	TAL A42 H
<b>Kcc</b> Short-circuit ratio	0.45	0.49	0.43	0.47	0.42
<b>Xd</b> Direct-axis synchro.reactance unsaturated	278	259	275	265	297
<b>Xq</b> Quadrature-axis synchro.reactance unsaturated	167	155	165	159	178
<b>T'do</b> No-load transient time constant	805	861	918	933	962
<b>X'd</b> Direct-axis transient reactance saturated	16.7	15.0	14.1	13.9	15.2
<b>T'd</b> Short-circuit transient time constant	50	50	50	50	50
<b>X''d</b> Direct-axis subtransient reactance saturated	9.0	8.1	7.6	7.5	8.2
<b>T''d</b> Subtransient time constant	5.0	5.0	5.0	5.0	5.0
<b>X''q</b> Quadrature-axis subtransient reactance saturated	12.7	11.4	10.7	10.6	11.5
<b>Xo</b> Zero sequence reactance saturated	0.9	0.9	0.9	0.9	11
<b>X2</b> Negative sequence reactance saturated	10.8	9.8	9.1	9.0	9.9
<b>Ta</b> Armature time constant	8	8	8	8	8

Other class H/400V data	TAL A42 C	TAL A42 E	TAL A42 F	TAL A42 G	TAL A42 H
<b>ms</b> Response time ( $\Delta U=20\%$ )	500	500	500	500	500
<b>W</b> No-load losses	749	840	923	1080	1176
<b>W</b> Heat dissipation	4070	4745	4909	5403	6337

Load shedding (SHUNT/AREP+) - kVA at P.F. = 0.8

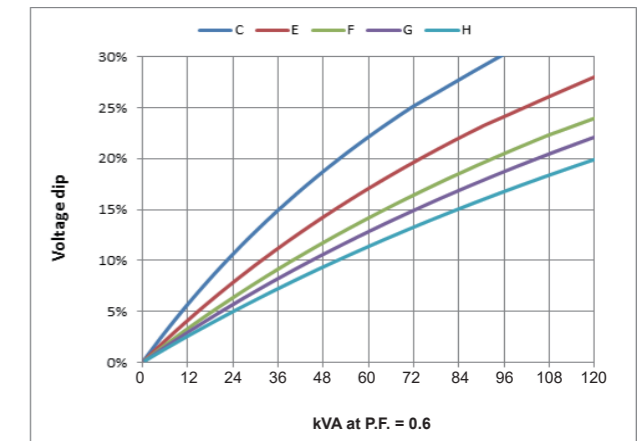
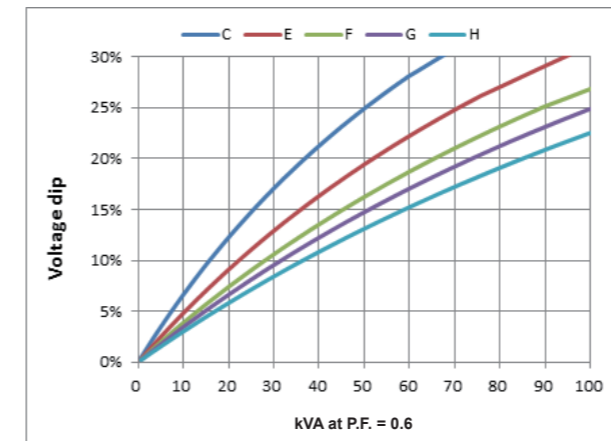

Motor starting (SHUNT/AREP+) - locked rotor kVA at P.F. = 0.6

- 1) For a starting P.F. other than 0.6, the starting kVA must be multiplied by  $K = \text{Sine P.F.} / 0.8$
- 2) For voltages other than 400V (Y), 230V ( $\Delta$ ) at 50 Hz, then kVA must be multiplied by  $(400/U)^2$  or  $(230/U)^2$ .



## Low Voltage Alternators - 4 pole

TAL A42 - Three-phase 30 to 63 kVA - 50 Hz / 36 to 75.6 kVA - 60 Hz

Efficiencies 480 V - 60 Hz (— P.F.: 0.8) (..... P.F.: 1) - 6 & 12-wire

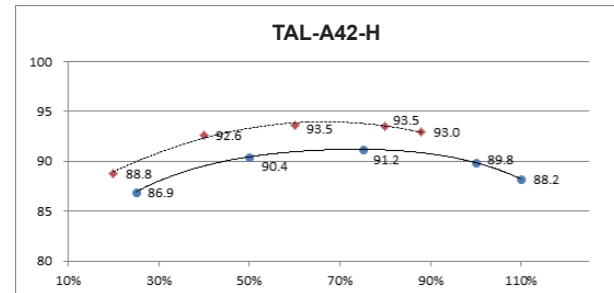
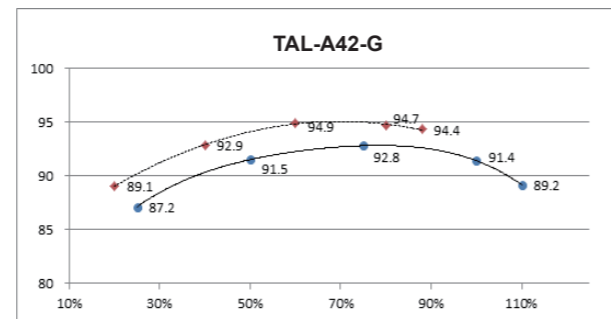
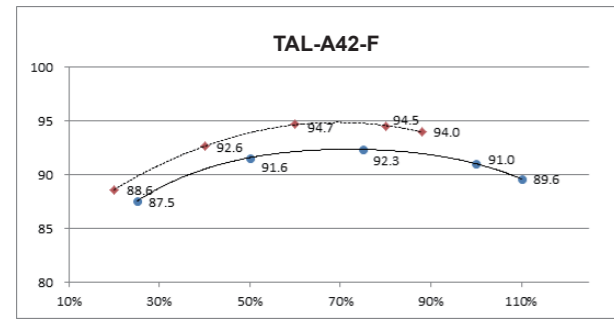
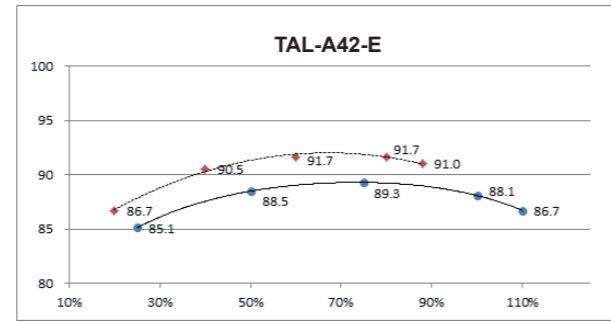
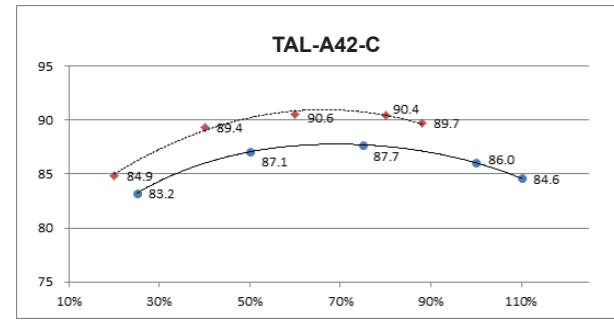

Reactances (%). Time constants (ms) - Class H / 480 V - 6 & 12 wire

	TAL A42 C	TAL A42 E	TAL A42 F	TAL A42 G	TAL A42 H
<b>Kcc</b> Short-circuit ratio	0.45	0.49	0.43	0.47	0.42
<b>Xd</b> Direct-axis synchro.reactance unsaturated	278	259	275	265	297
<b>Xq</b> Quadrature-axis synchro.reactance unsaturated	167	155	165	159	178
<b>T'do</b> No-load transient time constant	805	861	918	933	962
<b>X'd</b> Direct-axis transient reactance saturated	16.7	15.0	14.1	13.9	15.2
<b>T'd</b> Short-circuit transient time constant	50	50	50	50	50
<b>X''d</b> Direct-axis subtransient reactance saturated	9.0	8.1	7.6	7.5	8.2
<b>T''d</b> Subtransient time constant	5.0	5.0	5.0	5.0	5.0
<b>X''q</b> Quadrature-axis subtransient reactance saturated	12.7	11.4	10.7	10.6	11.5
<b>Xo</b> Zero sequence reactance saturated	0.9	0.9	0.9	0.9	11
<b>X2</b> Negative sequence reactance saturated	10.8	9.8	9.1	9.0	9.9
<b>Ta</b> Armature time constant	8	8	8	8	8

  

Other class H/480V data	TAL A42 C	TAL A42 E	TAL A42 F	TAL-A42-G	TAL A42 H
<b>ms</b> Response time ( $\Delta U=20\%$ )	500	500	500	500	500
<b>W</b> No-load losses	1078	1210	1329	1556	1693
<b>W</b> Heat dissipation	4688	4917	4273	4516	6870

## Low Voltage Alternators - 4 pole

TAL A42 - Three-phase 30 to 63 kVA - 50 Hz / 36 to 75.6 kVA - 60 Hz

Transient voltage variation 480V - 60 Hz - 6-wire

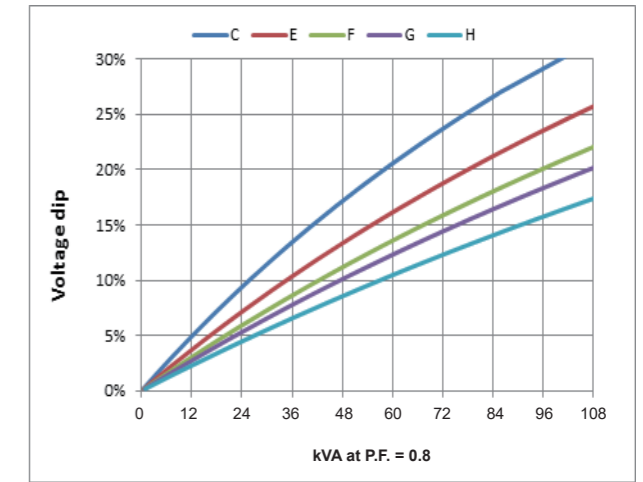
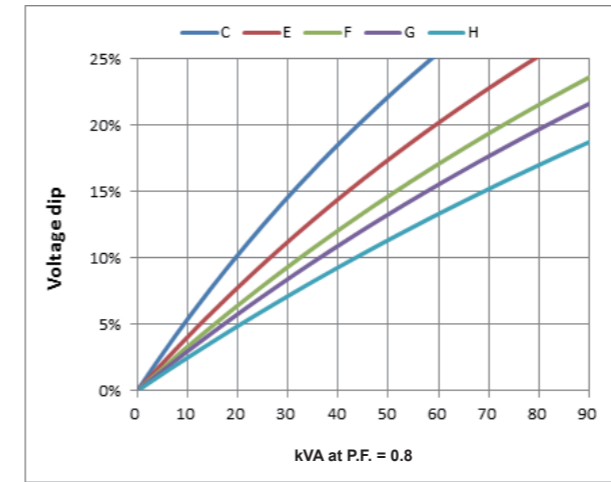

Phase loading (SHUNT/AREP+) - kVA at P.F. = 0.8

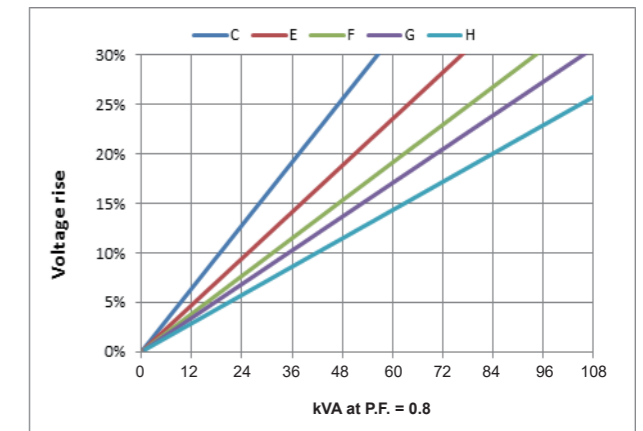
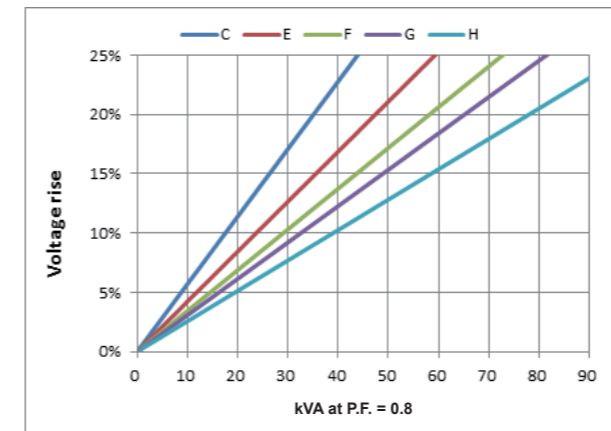

Load shedding (SHUNT/AREP+) - kVA at P.F. = 0.8

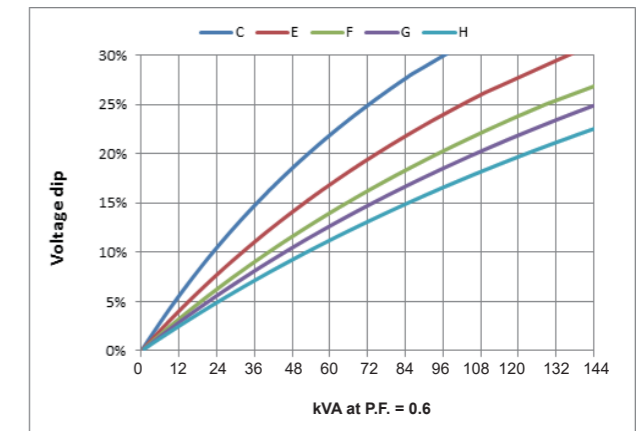
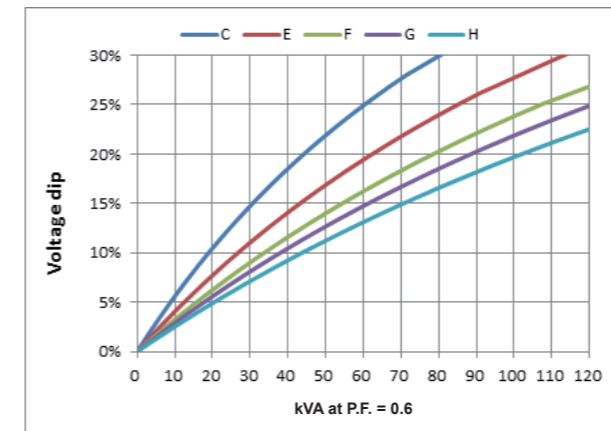

Motor starting (SHUNT/AREP+) - locked rotor kVA at P.F. = 0.6

- 1) For a starting P.F. other than 0.6, the starting kVA must be multiplied by  $K = \text{Sine P.F.} / 0.8$
- 2) For voltages other than 480V (Y), 277V ( $\Delta$ ), 240V (YY) at 60 Hz, then kVA must be multiplied by  $(480/U)^2$  or  $(277/U)^2$  or  $(240/U)^2$ .

## Low Voltage Alternators - 4 pole

### TAL A42 - Three-phase 30 to 63 kVA - 50 Hz / 36 to 75.6 kVA - 60 Hz

#### Single bearing general arrangement - 4, 6 & 12-wire

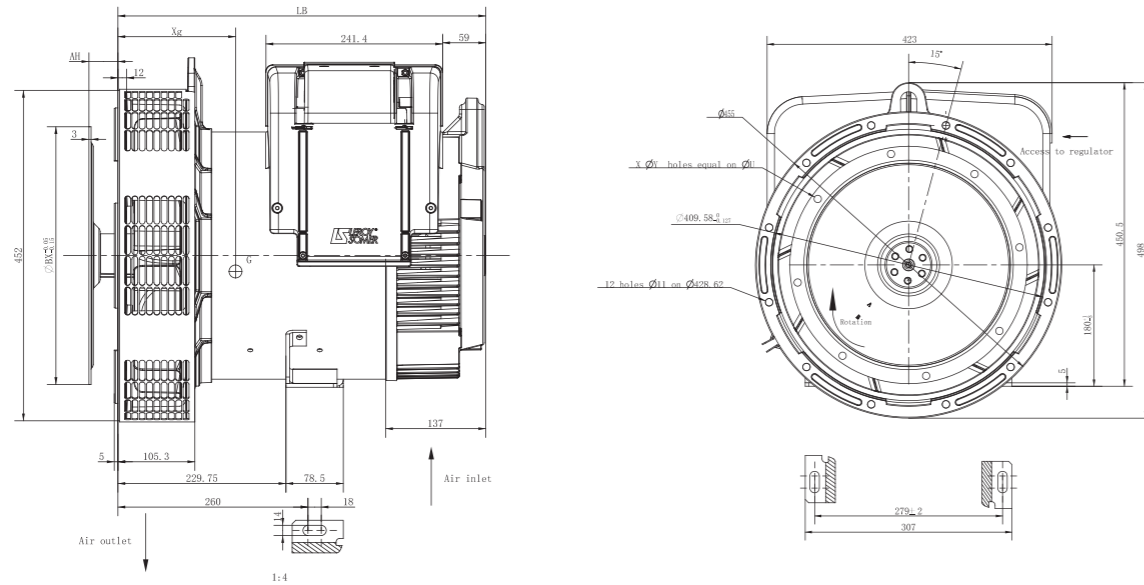

Dimensions (mm) and weight (kg)			DISC 11 1/2	DISC 10	DISC 8	DISC 7 1/2
Type	LB	Xg	Mass (kg)	J (kgm <sup>2</sup> )	J (kgm <sup>2</sup> )	J (kgm <sup>2</sup> )
TAL A42 C	503	242	120	0.2681	0.2561	0.2444
TAL A42 E	523	263	142	0.3324	0.3204	0.3087
TAL A42 F	588	287	171	0.3835	0.3715	0.3598
TAL A42 G	588	295	177	0.3957	0.3837	0.372
TAL A42 H	618	310	186	0.4415	0.4295	0.4178

Flex plate (mm)					
S.A.E.	BX	U	X	Y	AH
3-11 1/2	352.42	333.38	8	11	39.6
3-10	314.32	295.28	8	11	53.8
3-8	263.52	244.48	6	11	62
3-7 1/2	241.3	222.25	8	9	30.2

#### Torsional analysis data

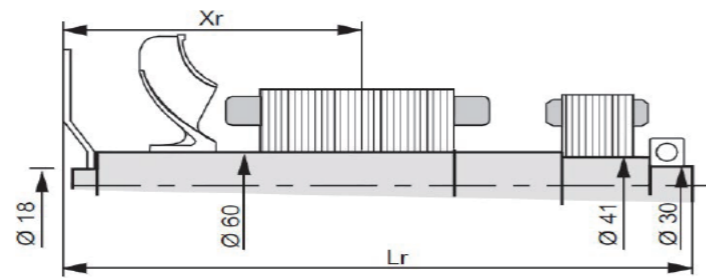

Type	Centre of gravity: $X_r$ (mm), Rotor length: $L_r$ (mm), Weight: $M$ (kg), Moment of inertia: $J$ (kgm <sup>2</sup> ): ( $4J = MD^2$ )															
	Flex Plate SAE7 1/2				Flex Plate SAE8				Flex Plate SAE10				Flex Plate SAE11 1/2			
	$X_r$	$L_r$	$M$	$J$	$X_r$	$L_r$	$M$	$J$	$X_r$	$L_r$	$M$	$J$	$X_r$	$L_r$	$M$	$J$
TAL A42 C	278.97	526.2	47.77	0.2407	308.13	558	48.09	0.2444	288.095	549.8	48.53	0.2561	280.91	535.6	49.03	0.2681
TAL A42 E	290.53	526.2	57.87	0.305	320.08	558	58.19	0.3087	299.416	549.8	58.63	0.3204	293.5	535.6	59.13	0.3324
TAL A42 F	321.11	611.2	67.82	0.3561	350.85	643	68.14	0.3598	340.644	634.8	68.58	0.3715	324.45	620.6	69.08	0.3835
TAL A42 G	326.09	611.2	70.82	0.3753	355.9	643	71.14	0.379	345.742	634.8	71.58	0.3907	329.6	620.6	72.08	0.4027
TAL A42 H	340.91	641.2	77.49	0.4141	370.82	673	77.81	0.4178	360.747	664.8	78.25	0.4295	344.67	650.6	78.75	0.4415

**NOTE** : Dimensions are for information only and may be subject to modifications. Contractual 2D/3D drawings can be downloaded from the Leroy-Somer site. The torsional analysis of the transmission is imperative. All values are available upon request.

## Low Voltage Alternators - 4 pole

### TAL A42 - S Dedicated single-phase 18 to 42 kVA - 50 Hz / 23 to 53 kVA - 60 Hz

#### General characteristics

Insulation class	H	Excitation system	SHUNT
Winding pitch	2/3 (wind. M 50 Hz, M1 60 Hz)	AVR type	R121
Number of wires	4	Voltage regulation (*)	± 1 %
Protection	IP 23	Total Harmonic Distortion THD (**) in no-load	< 3.5 %
Altitude	≤ 1000 m	Total Harmonic Distortion THD (**) in linear load	< 5 %
Overspeed	2250 R.P.M.	Waveform: NEMA = TIF (**)	< 100
Air flow (m <sup>3</sup> /s)	50 Hz: 0.10 - 60 Hz: 0.13	Waveform: I.E.C. = THF (**)	< 2 %

(\*) Steady state (\*\*) Total harmonic distortion between phases, no-load or on-load (non-distorting)

#### Ratings / Efficiencies 50 Hz - 1500 R.P.M. - Winding M

kVA / kW - P.F. = 1 (P.F. 0.8 : derating 15%)	Duty / T° C	Continuous / 40 °C		Continuous / 40 °C Stand-by / 40 °C	Stand-by / 27 °C		
	Class / T° K	H / 125° K	F / 105° K	H / 150° K	H / 163° K		
Serie (SE)		230 V	η %	230 V	230 V	230V	η %
Parallel (PA)		115 V	η %	115 V	115 V	115 V	η %
TAL A42 A-S		18	88.1	16.5	19	20	87.4
TAL A42 B-S		20.5	88.1	18.5	21.5	22.5	87.4
TAL A42 C-S		22.5	89	20.5	24	25	88.4
TAL A42 D-S		25	90.6	23	26.5	27.5	90.2
TAL A42 E-S		28	90.1	25.5	29.5	31	89.6
TAL A42 F-S		31.5	90.3	28.5	33.5	34.5	89.8
TAL A42 G-S		35	90.4	32	37	38.5	89.9
TAL A42 H-S		42	90.5	38	44.5	46	90

#### Ratings / Efficiencies 60 Hz - 1800 R.P.M. - Winding M1

kVA / kW - P.F. = 1 (P.F. 0.8 : derating 15%)	Duty / T° C	Continuous / 40 °C		Continuous / 40 °C Stand-by / 40 °C	Stand-by / 27 °C		
	Class / T° K	H / 125° K	F / 105° K	H / 150° K	H / 163° K		
Serie (SE)		240 V	η %	240 V	240 V	240V	η %
Parallel (PA)		120 V	η %	120 V	120 V	120 V	η %
TAL A42 A-S		23	88.3	21	24.5	25.5	87.7
TAL A42 B-S		26	88.3	23.5	27.5	28.5	87.6
TAL A42 C-S		29	89	26	30.5	32	88.5
TAL A42 D-S		31.5	90.4	28.5	33.5	34.5	90
TAL A42 E-S		36	89.8	33	38	39.5	89.2
TAL A42 F-S		40	90	36.5	42.5	44	89.5
TAL A42 G-S		47	90	43	50	51	89.5
TAL A42 H-S		53	90.5	48	56	58	90

#### Starting motor 230V - 50Hz

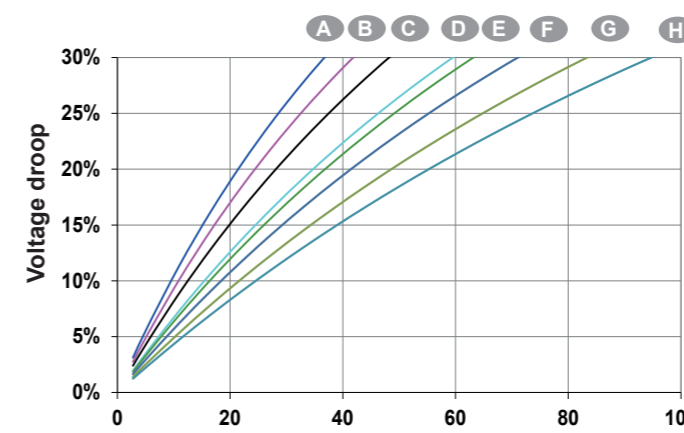

#### Starting motor 240V - 60Hz

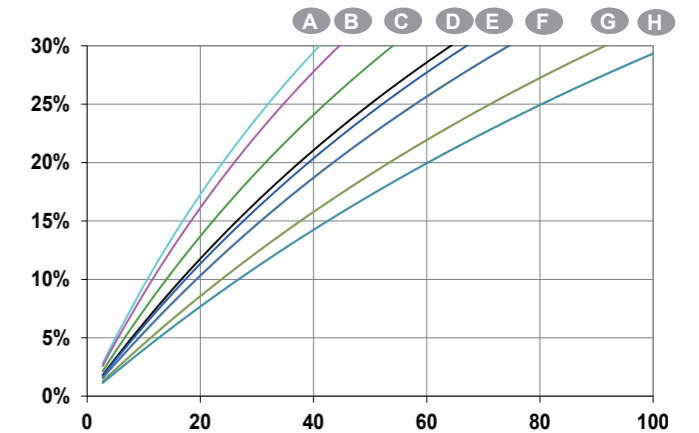

Locked rotor kVA at PF : 0.9





## Low Voltage Alternators - 4 pole

TAL A44 - Three-phase 85 to 200 kVA - 50 Hz / 102 to 250 kVA - 60 Hz

Efficiencies 400 V - 50 Hz (— P.F.: 0.8) (..... P.F.: 1) - 6 & 12-wire

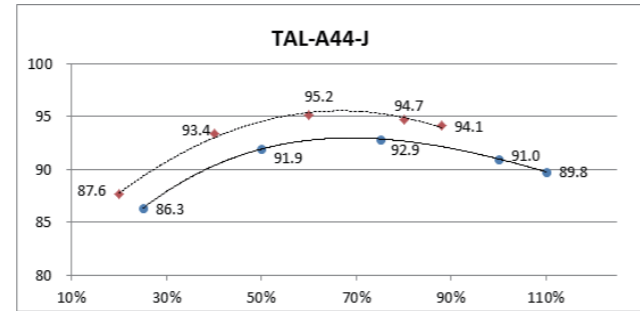
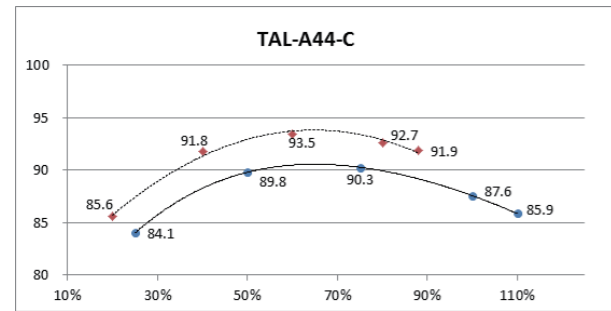

## Low Voltage Alternators - 4 pole

TAL A44 - Three-phase 85 to 200 kVA - 50 Hz / 102 to 250 kVA - 60 Hz

Efficiencies 480 V - 60 Hz (— P.F.: 0.8) (..... P.F.: 1) - 6 & 12-wire

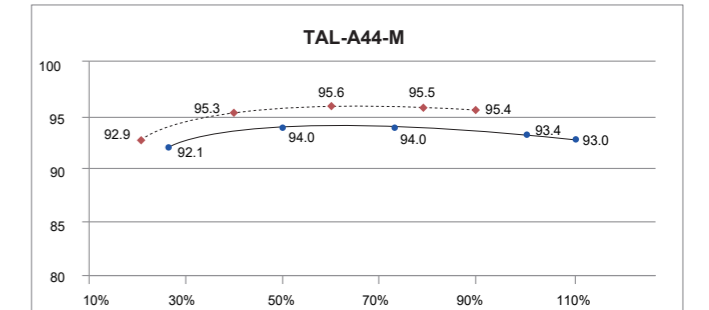
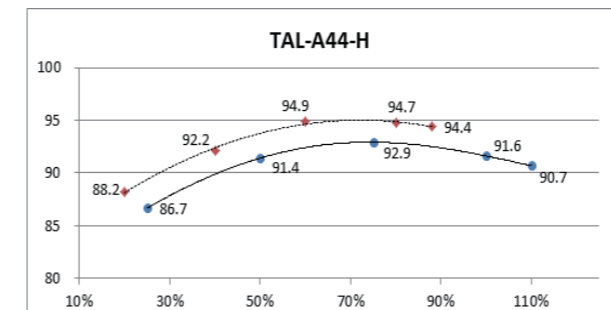
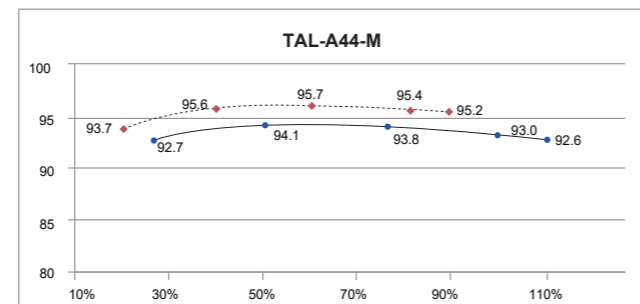
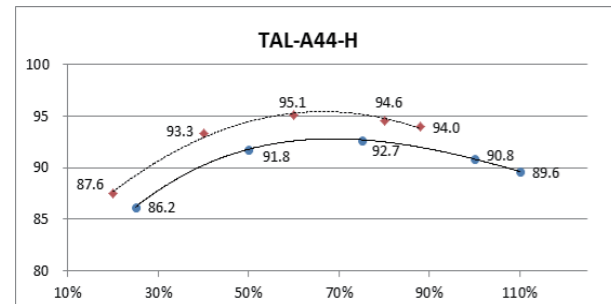
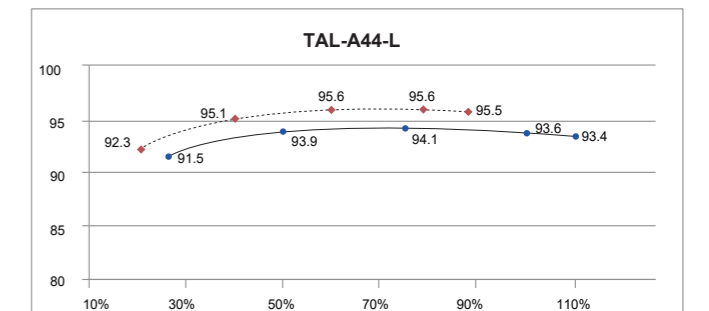
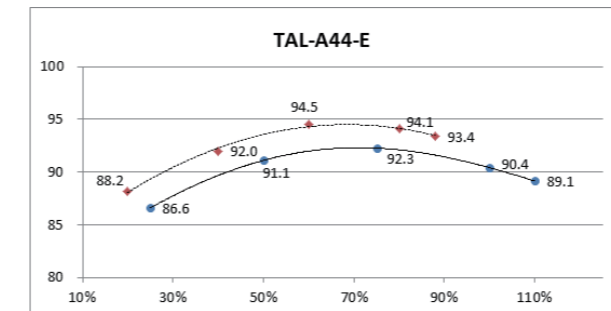
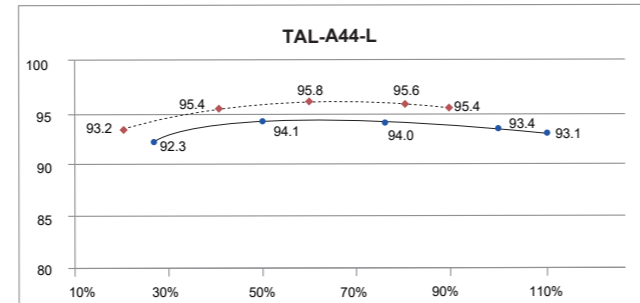
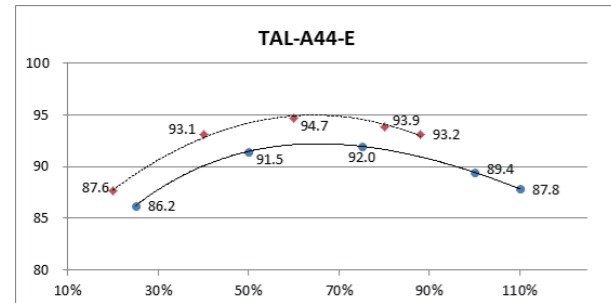
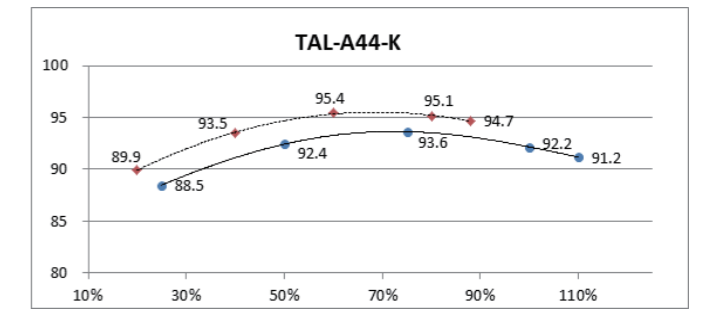
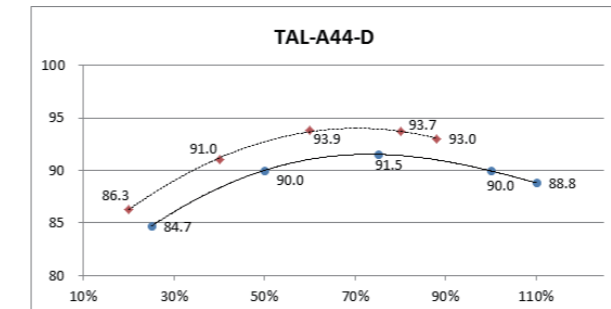
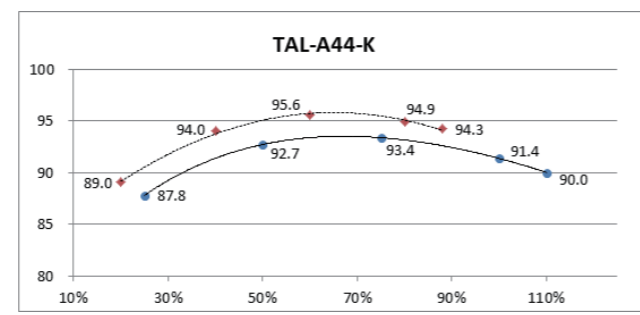
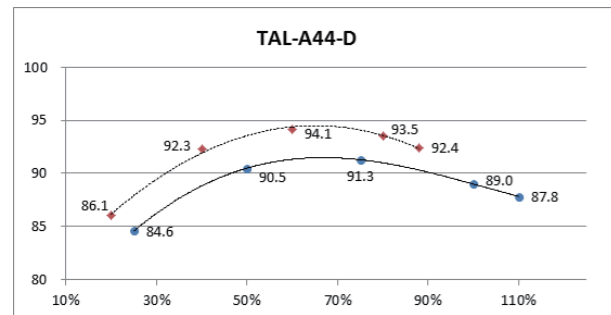
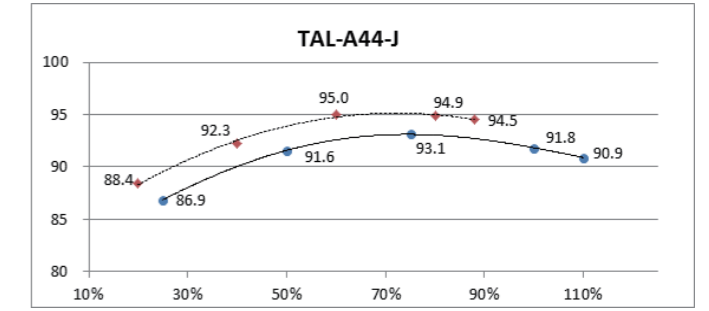
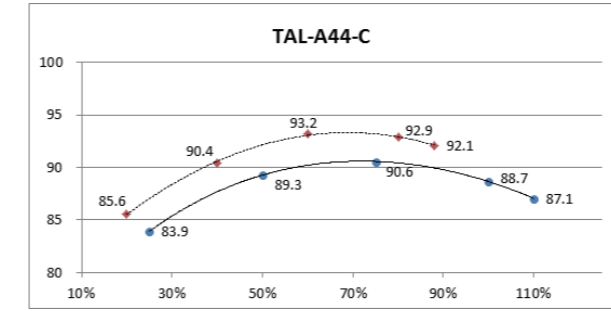



## Low Voltage Alternators - 4 pole

### TAL A44 - Three-phase 85 to 200 kVA - 50 Hz / 102 to 250 kVA - 60 Hz

#### Reactances (%). Time constants (ms) - Class H / 400 V - 6 & 12-wire

	TAL A44 C	TAL A44 D	TAL A44 E	TAL A44 H	TAL A44 J	TAL A44 K	TAL A44 L	TAL A44 M
<b>Kcc</b> Short-circuit ratio	0.50	0.59	0.4	0.56	0.61	0.37	0.37	0.33
<b>Xd</b> Direct-axis synchro. reactance unsaturated	321	303	365	307	290	373	373	381
<b>Xq</b> Quadrature-axis synchro. reactance unsaturated	193	182	219	184	174	224	175	194
<b>T'do</b> No-load transient time constant	1747	1796	2211	1952	2013	2077	2025	2025
<b>X'd</b> Direct-axis transient reactance saturated	17.7	17.2	16.4	16.1	15.0	16.6	16.9	18.8
<b>T'd</b> Short-circuit transient time constant	100	100	100	100	100	100	100	100
<b>X''d</b> Direct-axis subtransient reactance saturated	10.6	10.3	9.8	9.6	9.0	9.9	10.1	11.3
<b>T''d</b> Subtransient time constant	10.0	10.0	10.0	10.0	10.0	10.0	10.0	10.0
<b>X''q</b> Quadrature-axis subtransient reactance saturated	21.0	20.4	19.4	19.1	17.8	19.7	19.7	21.9
<b>Xo</b> Zero sequence reactance saturated	0.6	0.6	0.6	0.6	0.6	0.7	0.7	0.78
<b>X2</b> Negative sequence reactance saturated	15.8	15.4	14.6	14.4	13.4	14.8	14.95	16.62
<b>Ta</b> Armature time constant	15	15	15	15	15	15	15	15

Other class H/400V data	TAL A44 C	TAL A44 D	TAL A44 E	TAL A44 H	TAL A44 J	TAL A44 K	TAL A44 L	TAL A44 M
<b>ms</b> Response time ( $\Delta U=20\%$ )	500	500	500	500	500	500	500	500
<b>W</b> No-load losses	1890	2213	2503	2436	2533	2954	2665	2665
<b>W</b> Heat dissipation	9625	9888	11256	11145	11868	12796	10134	11895

## Low Voltage Alternators - 4 pole

### TAL A44 - Three-phase 85 to 200 kVA - 50 Hz / 102 to 250 kVA - 60 Hz

#### Reactances (%). Time constants (ms) - Class H / 480 V - 6 & 12-wire

	TAL A44 C	TAL A44 D	TAL A44 E	TAL A44 H	TAL A44 J	TAL A44 K	TAL A44 L	TAL A44 M
<b>Kcc</b> Short-circuit ratio	0.50	0.59	0.4	0.56	0.61	0.37	0.36	0.32
<b>Xd</b> Direct-axis synchro. reactance unsaturated	321	303	365	307	290	373	358	397
<b>Xq</b> Quadrature-axis synchro. reactance unsaturated	193	182	219	184	174	224	182	202
<b>T'do</b> No-load transient time constant	1747	1796	2211	1952	2013	2077	2025	2025
<b>X'd</b> Direct-axis transient reactance saturated	17.7	17.2	16.4	16.1	15.0	16.6	17.6	19.6
<b>T'd</b> Short-circuit transient time constant	100	100	100	100	100	100	100	100
<b>X''d</b> Direct-axis subtransient reactance saturated	10.6	10.3	9.8	9.6	9.0	9.9	10.6	11.7
<b>T''d</b> Subtransient time constant	10.0	10.0	10.0	10.0	10.0	10.0	10.0	10.0
<b>X''q</b> Quadrature-axis subtransient reactance saturated	21.0	20.4	19.4	19.1	17.8	19.7	20.5	22.8
<b>Xo</b> Zero sequence reactance saturated	0.6	0.6	0.6	0.6	0.6	0.7	0.73	0.81
<b>X2</b> Negative sequence reactance saturated	15.8	15.4	14.6	14.4	13.4	14.8	15.59	17.32
<b>Ta</b> Armature time constant	15	15	15	15	15	15	15	15

Other class H/480V data	TAL A44 C	TAL A44 D	TAL A44 E	TAL A44 H	TAL A44 J	TAL A44 K	TAL A44 L	TAL A44 M
<b>ms</b> Response time ( $\Delta U=20\%$ )	500	500	500	500	500	500	500	500
<b>W</b> No-load losses	2722	3187	3604	3508	3647	4253	3923	3923
<b>W</b> Heat dissipation	10395	10667	12217	12105	12863	13807	12145	14130

## Low Voltage Alternators - 4 pole

TAL A44 - Three-phase 85 to 200 kVA - 50 Hz / 102 to 250 kVA - 60 Hz

### Transient voltage variation 400V - 50 Hz - 12-wire

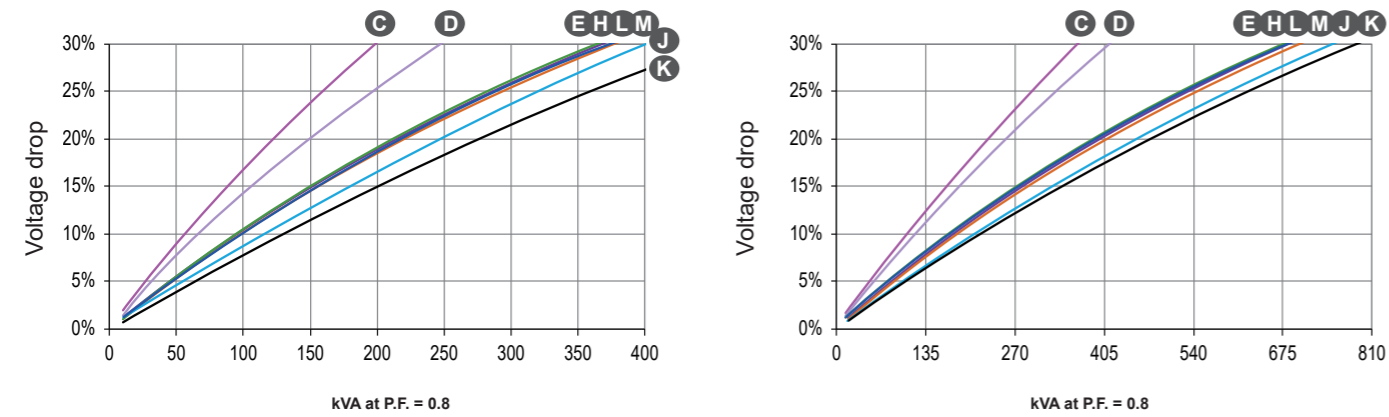

Phase loading (SHUNT/AREP+) - kVA at P.F. = 0.8

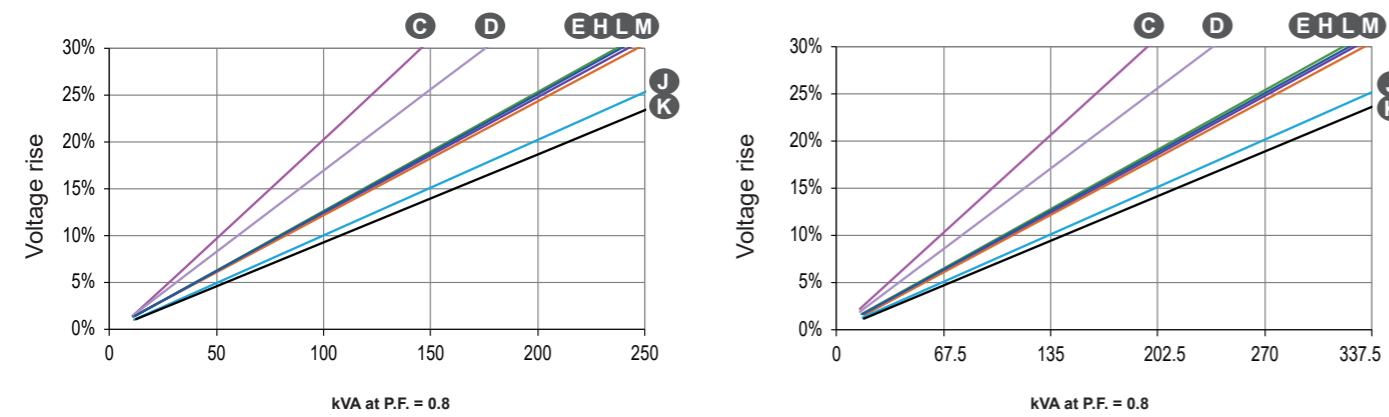

Load shedding (SHUNT/AREP+) - kVA at P.F. = 0.8

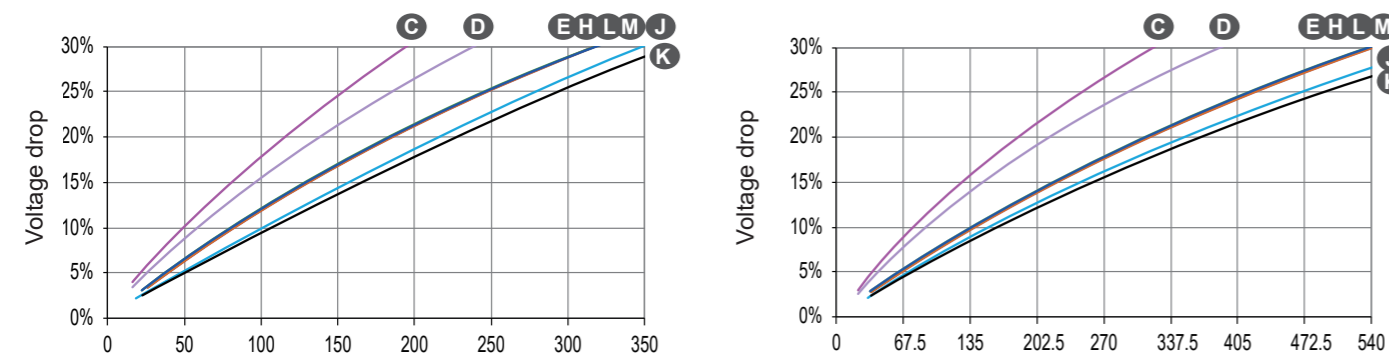

Motor starting (SHUNT/AREP+) - locked rotor kVA at P.F. = 0.6

- 1) For a starting P.F. other than 0.6, the starting kVA must be multiplied by  $K = \text{Sine P.F.} / 0.8$
- 2) For voltages other than 400V (Y), 230V ( $\Delta$ ) at 50 Hz, then kVA must be multiplied by  $(400/U)^2$  or  $(230/U)^2$ .

## Low Voltage Alternators - 4 pole

TAL A44 - Three-phase 85 to 200 kVA - 50 Hz / 102 to 250 kVA - 60 Hz

### Transient voltage variation 480V - 60 Hz - 6-wire

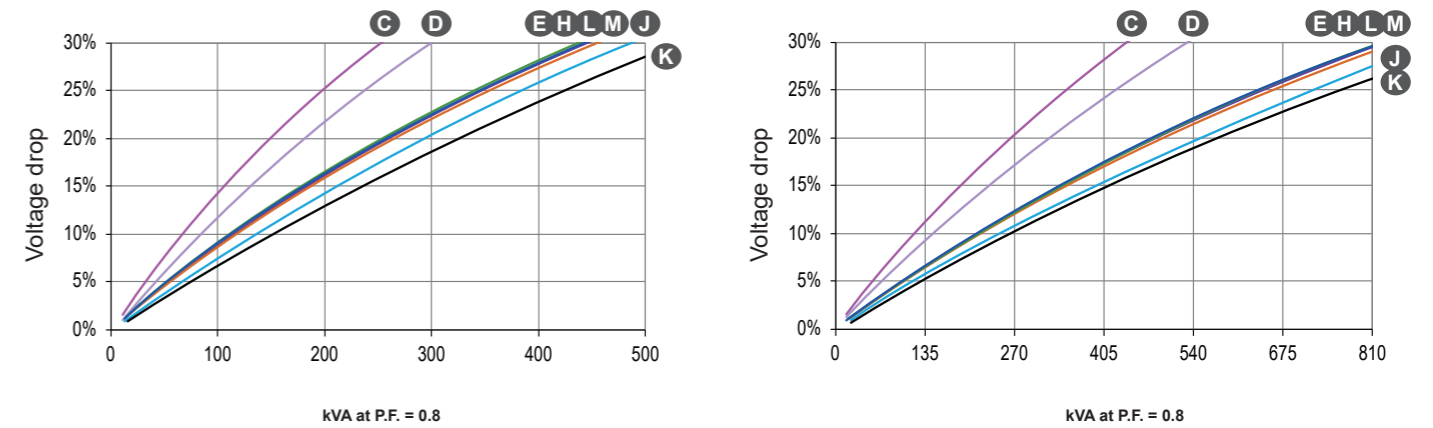

Phase loading (SHUNT/AREP+) - kVA at P.F. = 0.8

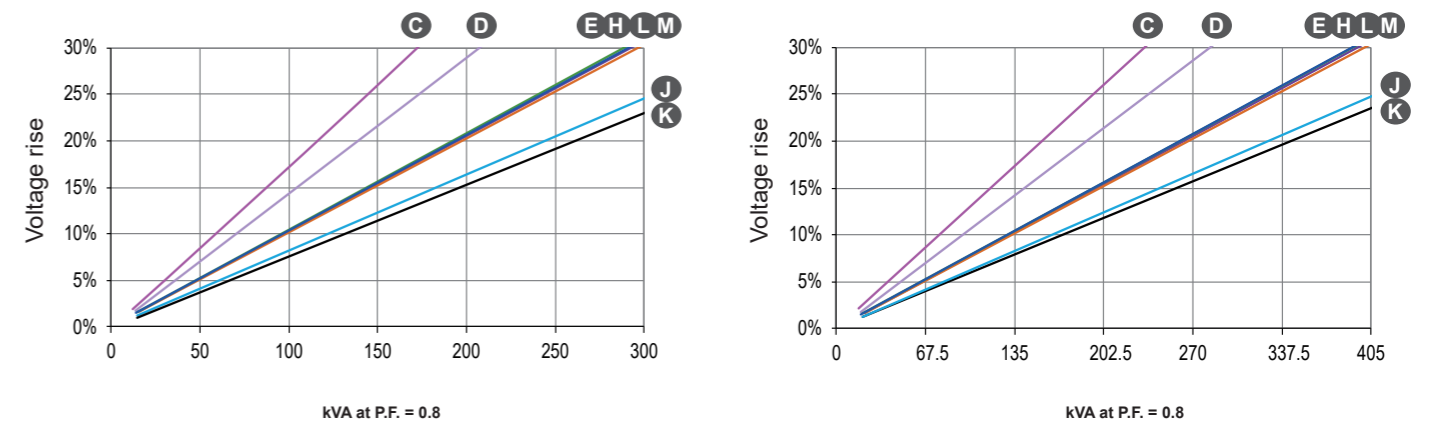

Load shedding (SHUNT/AREP+) - kVA at P.F. = 0.8

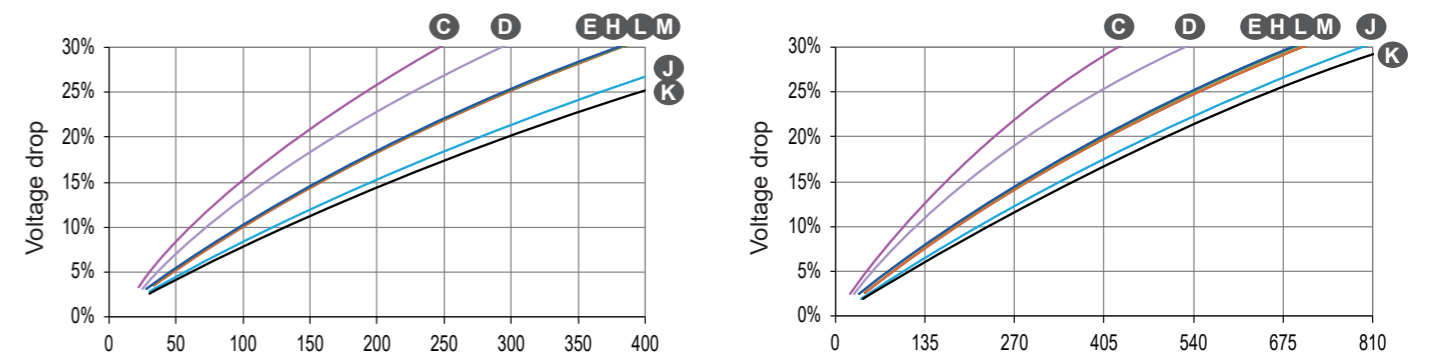

Motor starting (SHUNT/AREP+) - locked rotor kVA at P.F. = 0.6

- 1) For a starting P.F. other than 0.6, the starting kVA must be multiplied by  $K = \text{Sine P.F.} / 0.8$
- 2) For voltages other than 480V (Y), 277V ( $\Delta$ ), 240V (YY) at 60 Hz, then kVA must be multiplied by  $(480/U)^2$  or  $(277/U)^2$  or  $(240/U)^2$ .

## Low Voltage Alternators - 4 pole

TAL A44 - Three-phase 85 to 200 kVA - 50 Hz / 102 to 250 kVA - 60 Hz

### TAL A44 C

Symmetrical - - - - -  
Asymmetrical - - -

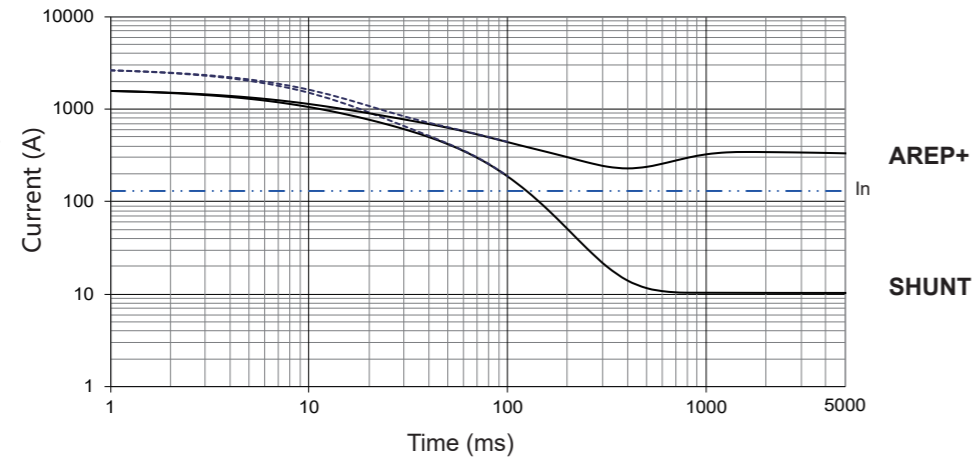

### TAL A44 D

Symmetrical - - - - -  
Asymmetrical - - -

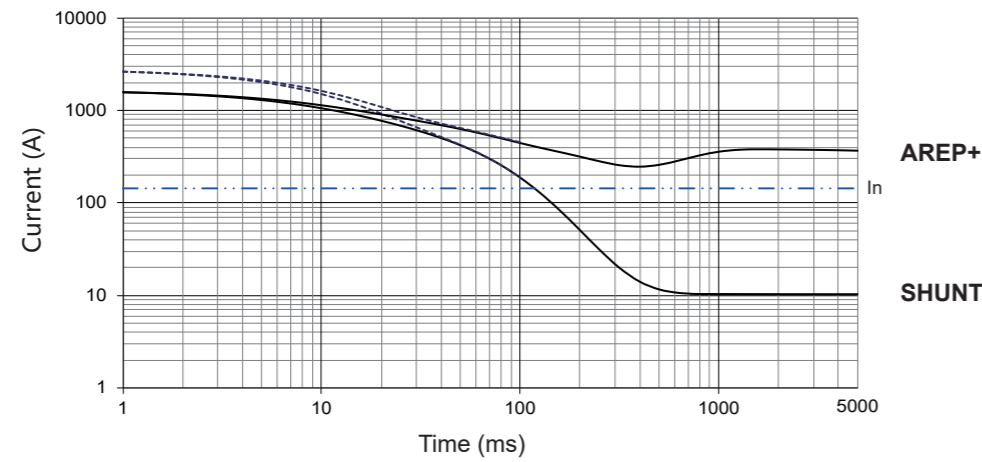

### TAL A44 E

Symmetrical - - - - -  
Asymmetrical - - -

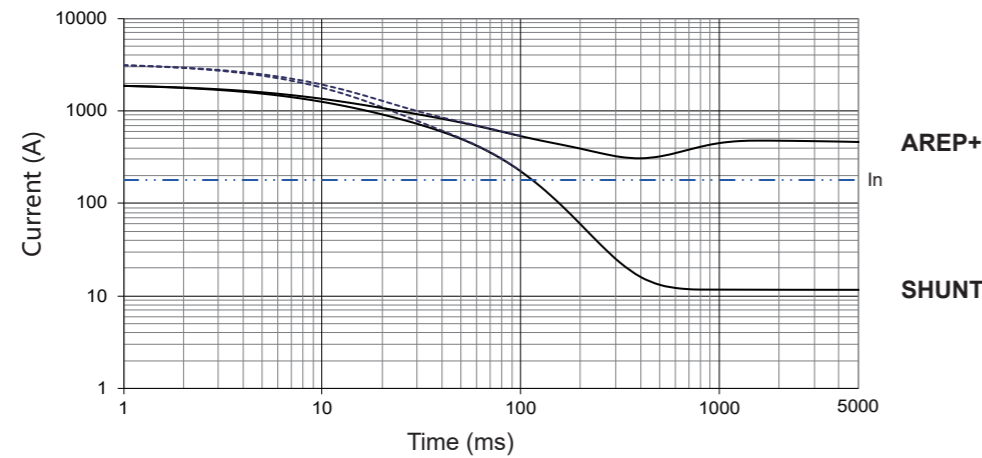

#### Influence due to connection

For (Δ) connection, use the following multiplication factor:  
- Current value x 1.732.

## Low Voltage Alternators - 4 pole

TAL A44 - Three-phase 85 to 200 kVA - 50 Hz / 102 to 250 kVA - 60 Hz

### TAL A44 H

Symmetrical - - - - -  
Asymmetrical - - -

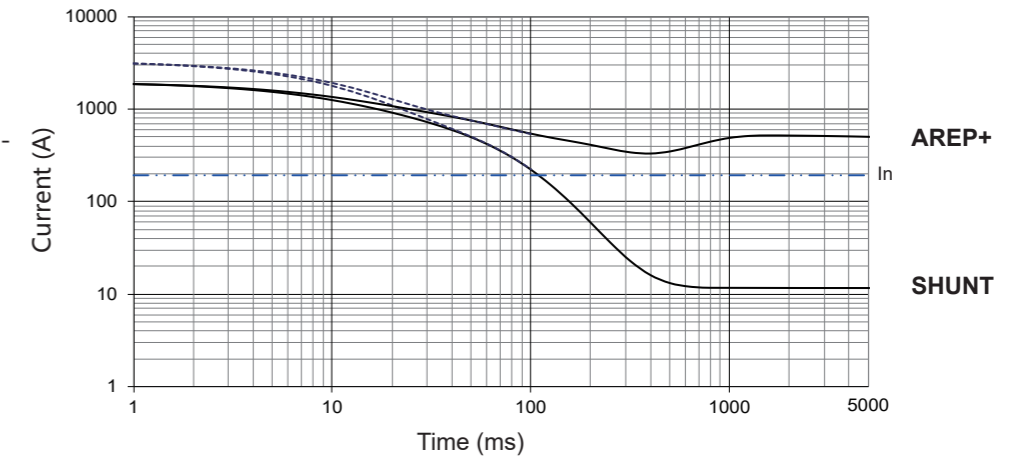

### TAL A44 J

Symmetrical - - - - -  
Asymmetrical - - -

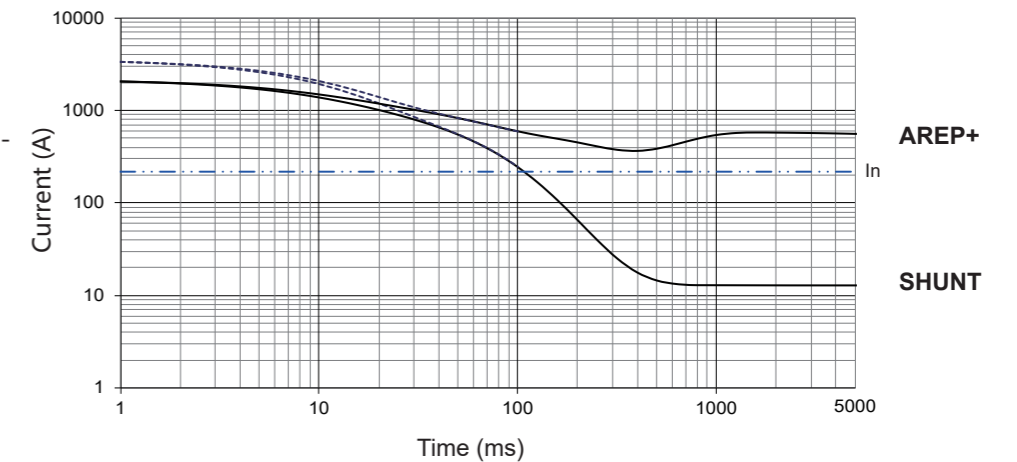

### TAL A44 K

Symmetrical - - - - -  
Asymmetrical - - -

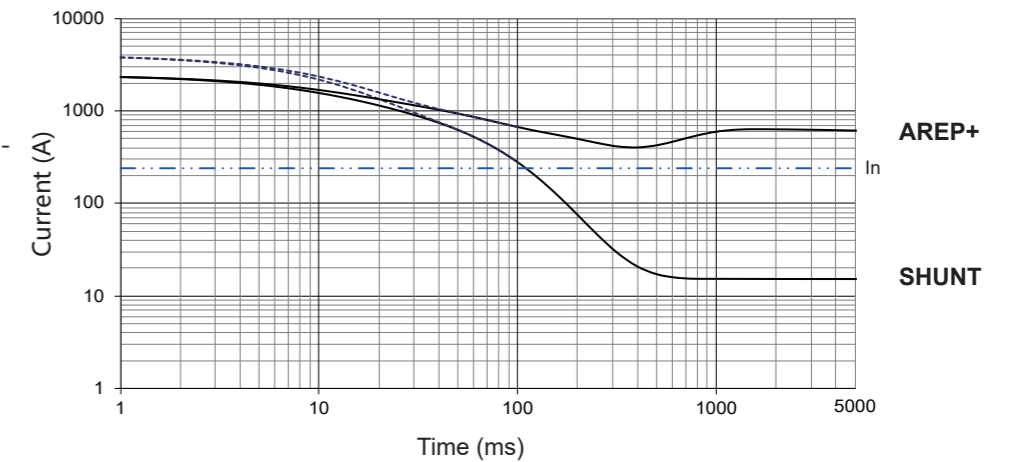

#### Influence due to short-circuit

Curves are based on a three-phase short-circuit.  
For other types of short-circuit,  
use the following multiplication factors.

	3 - phase	2 - phase L / L	1 - phase L / N
Instantaneous (max.)	1	0.87	1.3
Continuous	1	1.5	2.2
Maximum duration		1.5	





**LEROY-SOMER**<sup>™</sup>

[www.leroy-somer.com/epg](http://www.leroy-somer.com/epg)

**Connect with us at:**

[Twitter.com/EPG\\_Alternators](https://twitter.com/EPG_Alternators)

[Facebook.com/LeroySomer.EPG](https://facebook.com/LeroySomer.EPG)

[Youtube.com/LeroySomerOfficiel](https://youtube.com/LeroySomerOfficiel)

[Linkedin.com/company/44575](https://linkedin.com/company/44575)

[WeChat.com/Leroy-SomerEPG](https://wechat.com/Leroy-SomerEPG)



Scan the QR Code for  
more information



***Nidec***  
**All for dreams**

Moteurs Leroy-Somer SAS. Headquarters: Bd Marcellin Leroy, CS 10015, 16915 Angoulême Cedex 9,  
France. Share Capital: 38 679 664 €, RCS Angoulême 338 567 258.